

Water chillers and heat pumps catalogue

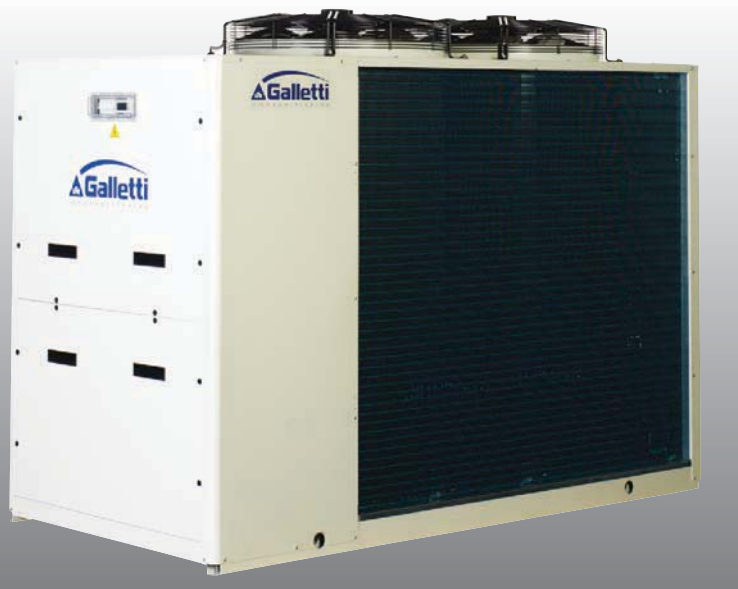

MPI-DC	Package air-cooled water chillers and heat pumps with inverter compressor 6 models from 8 to 29 kW	page 6
MPE	Package air-cooled water chillers and heat pumps 25 models from 4 to 76 kW	page 10
MCC	Package air-cooled water chillers and heat pumps with centrifugal fans 10 models from 6 to 40 kW	page 14
MCW	Package water-cooled chillers and heat pumps 11 models, 2 versions from 5 to 40 kW	page 17
MCR	Scroll compressor condenserless chillers 11 models, 2 versions from 5 to 34 kW	page 20
MSHRT	Air-water compact heat pumps 3 models from 6 to 9 kW	page 21
MTE	Air cooled condensing units 29 models from 5 to 213 kW	page 23

HIWARM	Total heat recovery multifunctional package air to water heat pumps, full inverter, split configuration 3 models from 12 to 33 kW	page 25
MCP	Total heat recovery multifunctional package air to water heat pumps 14 models from 7 to 41 kW	page 31
BUFFER TANKS	Buffer water tanks for rapid production of DHW 11 models from 300 to 800 litres	page 34
LCP	Total heat recovery multifunctional package air to water heat pumps 16 models from 50 to 320 kW	page 45
LEP	Total heat recovery multifunctional package water to water heat pumps 19 models from 40 to 420 kW	page 50
MSHTJ	Air-water compact heat pumps, heating only 2 models from 14 to 20 kW	page 53
EMC	Tank module with electric heating elements	page 55

LCE	Package air-cooled water chillers and heat pumps 18 models, 6 versions, from 40 to 360 kW	page 57
LSE	Package air-cooled water chillers and heat pumps 14 models, 4 versions from 360 to 1200 kW	page 65
LEW	Package water-cooled chillers and heat pumps 24 models, 2 versions from 50 to 680 kW	page 70
LER	Scroll compressor condenserless chillers 19 models, 2 versions from 45 to 400 kW	page 76
CONTROLLERS	Network cards, Mychiller and Mychiller DHW remote control	page 80

small systems

MPI DC

MPE

MCC

MCW

MCR

MSHRT

MTE

MPI DC WATER CHILLERS AND HEAT PUMPS INVERTER DC

- > R410A
- > CONTINUOUS MODULATION OF CAPACITY FROM 30% TO 100%
- > WATER PRODUCED UP TO 58°C
- > HEAT PUMP OPERATION AT TEMPERATURES AS LOW AS -15°
- > SCROLL OR TWIN ROTARY COMPRESSOR WITH PERMANENT MAGNETS ELECTRIC SYNCHRONOUS MOTOR
- > ELECTRONIC EXPANSION VALVE
- > MODULATING HYDRAULIC PUMP

The actual thermal load of an air conditioning system is less than 60% of the rated load capacity 90% of the time.

In low-powered installations with a small number of indoor units and a low water content, operation under partial load conditions is particularly critical. In order to ensure that the system works correctly, it is thus necessary to vary the power output by the chiller.

The inverter controller acts on the compressor rpm by modulating the refrigerant mass, cooling capacity and input power.

The operating logic of MPI DC units allows an accurate adjustment of the outlet water temperature according to the thermal load conditions:

The PID control algorithm makes it possible to regulate the water temperature within +/- 15%.

The inverter controller allows to adjust the capacity and the input of the compressor to the actual thermal load and makes it possible to considerably reduce electrical intakes at the compressor start-up (reduction of starting currents) and during the operation under partial loads.

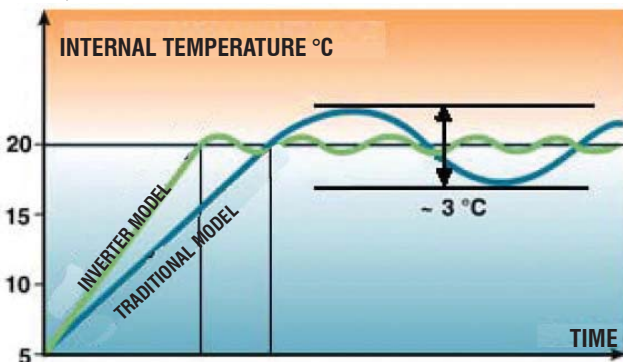

The spinning airtight scroll compressors (for models from MPI014 DC to MPI029 DC) or Twin Rotary compressors (for models from MPI08 DC to MPI010 DC) are equipped with motor protection against overheating and overcurrents.

Mounted on anti-vibration supports, complete with oil charge, they are enclosed in a soundproofed compartment and equipped with an automatically controlled oil heating system to avoid oil dilution by the refrigerant when the compressor is stopped.



The compressor motor is a permanent magnets, brushless, alternating current motor controlled by a trapezoidal wave driver operating in the frequency field ranging from 30 to 120 Hz (BLDC "Brushless Direct Current" Technology)

The electronic control system allows the setpoint to be adjusted automatically according to the outdoor temperature in order to reduce consumption and broaden the working temperature range.



The condensation control adjusts fan speed to actual operating conditions. This results in better working conditions, reduction of sound levels under partial load conditions and possibility of operating in cooling mode beyond conventional working limits (up to an outdoor air temperature of -10°C).



During heat pump operation, the exclusive smart defrost system can correctly identify an impairment of performance in the outdoor exchanger due to the formation of ice and minimise the process time in relation to normal operation of the unit.

STRUCTURE

Painted galvanised sheet steel structure (RAL9002) for an attractive look and effective resistance to corrosive agents.

Fastening devices are made of non-oxidizable materials, or carbon steel that has undergone surface-passivating treatments.

The compressor compartment is completely sealed and may be accessed on 3 sides thanks to easy-to-remove panels that greatly simplify maintenance and/or inspection.

Sound insulation, available on request, can further reduce the noise emissions of the unit.

CUSTOMISED HYDRONIC KITS

- High head modulating pump made entirely of stainless steel, already configured for use with mixtures of water and ethylene glycol up to 35% and provided with internal thermal protection. It is housed in the compressor compartment and is easy to reach thanks to the removable perimeter panels.
- Expansion tank
- Safety valve
- Filling cock (included)
- Automatic vent valve
- Water differential pressure switch and outlet water temperature probe with anti-freeze thermostat function
- Mechanical Y filter supplied as a standard feature on all models to protect the evaporator (included)

Cooling circuit

- BLDC-type compressor housed in a compartment that can be sound insulated.
- Brazed plate heat exchangers made of AISI 316 stainless steel and optimised for use with R410A.
- Finned block condenser with 8 mm copper piping and aluminium fins, characterised by ample heat exchange surfaces
- Dehydrating filter
- Flow indicator with humidity indicator
- Electronically controlled electric thermostatic valve, with external equalisation and integrated MOP function
- Cycle-reversing valve (MPI DC H)
- Single-acting valves (MPI DC H)
- Liquid receiver (MPI DC H)
- High and low pressure switches
- Safety valve
- Schrader valves for checks and/or maintenance
- Refrigerant pressure gauges (optional)

Fan drive assembly

Electric fan with 6-pole external rotor motor directly keyed to the axial fan, with internal thermal protection on the windings, complete with safety grille and dedicated supporting structure.

The fan is housed in a special compartment having a profile designed to optimise ventilation.

The use of finned block heat exchangers with 8mm diameter pipes reduces pressure drops on the air side, thus significantly improving the noise levels of the units.

The condensation control system continuously and automatically regulates the fan speed, further limiting the noise emissions of the unit during nighttime operation and under partial load conditions.

Made of 8mm diameter copper pipes and aluminium fins, generously sized. The special engineering of the heat exchangers allows defrost cycles to be carried out at maximum speed in the models with heat pump operation, which brings clear benefits in terms of the integrated efficiency of the whole cycle.

ELECTRONIC MICROPROCESSOR CONTROL

The electronic control enables the complete control of the MPI DC unit. It can be easily accessed through a polycarbonate flap with IP65 protection rating.



The modulation of capacity enables the unit to operate even in systems where the water content is low, without the use of an inertial water buffer tank. By reading the outdoor air temperature, it can automatically change the setpoint to adapt it to the outdoor load conditions or keep the unit running even in the harshest winter conditions.

Main functions:

- Continuous modulation of compressor capacity
- Control of outlet temperature
- Control over the temperature of water entering the evaporator
- Defrosting management (MPI DC-H)
- Control of fan speed
- Complete alarm management
- Dynamic control of the setpoint according to the outdoor air temperature
- Can be connected to an RS485 serial line for supervisory / teleassistance operation
- Option of connecting a remote terminal that duplicates the control functions
- Control of pump speed

Devices controlled:

- Compressor
- Fans
- Cycle-reversing valve (MPI DC H)
- Water circulation pump
- Antifreeze heating elements (optional)
- Alarm signalling relay

ELECTRIC CONTROL BOARD

Electric control board constructed and wired in accordance with the Directive on electromagnetic compatibility and related standards. Made of steel sheet, it is also protected by the enclosing panels of the unit.

OPTIONS

- Water storage
- Low noise execution
- Refrigerant pressure gauges
- Antifreeze heating elements on the water circuit
- Special exchangers (hydrophilic treatment, copper-copper, cataphoresis, anti-corrosion)



ACCESSORIES AVAILABLE

- Remote control boards
- Base vibration dampers
- Metal grilles to protect exchangers
- EC fans

RATED TECHNICAL DATA OF WATER CHILLERS

MPI DC - C		010 M	014	018	023	029
Power supply	V-ph-Hz	230-1-50	400-3N-50	400-3N-50	400-3N-50	400-3N-50
Rated cooling capacity	kW	10,6	14,3	18,2	22,9	29,1
Total power input	kW	3,35	4,78	7,63	7,77	12,3
EER (rated capacity)		3,16	2,99	2,39	2,95	2,37
Total input power with pump	kW	3,6	5,3	8,2	8,3	12,9
Maximum power input	kW	5,6	7,1	10,7	10,8	21,9
Maximum absorbed current	A	26,6	20,0	22,0	28,5	43,0
Starting current	A	10	10	10	10	10
No. of compressors / circuits		1 / 1	1 / 1	1 / 1	1 / 1	1 / 1
Refrigerant charge	kg	3,5	4,1	4,1	5,7	5,7
High / low pressure switch	bar,g	42 / 2	42 / 2	42 / 2	42 / 2	42 / 2
No. of axial fans		2	2	2	4	4
Air flow rate	m ³ /h	6.939	6.939	6.939	11.438	11.438
Water flow rate	l/h	1826	2454	3132	3935	4992
Diameter of water connections	inches	1 1/4	1 1/4	1 1/4	1 1/4	1 1/4
Pressure drop, water side	kPa	23	35	35	36	36
Available head	kPa	130	120	120	98	98
Water content, excluding optionals	dm ³	3,0	3,0	3,0	5,0	5,0
Expansion tank	dm ³	5	5	5	5	5
Buffer tank	dm ³	30	30	30	50	50
Height	mm	1250	1250	1250	1300	1300
Length	mm	1220	1220	1220	1565	1565
Depth	mm	560	560	560	600	600
Sound power level	dB(A)	70	71	71	74	74
Sound pressure level	dB(A)	42	43	43	46	46
Transport weight*	kg	210	210	210	285	285
Operating weight*	kg	235	235	235	335	335

* Weights refer to model with pump and buffer tank

- Cooling capacity: outdoor air temperature 35°C, water temperature 12°C -7°C

- Sound power measured according to standards ISO 3741 - ISO 3744 and EN 29614-1

- Sound pressure measured at a distance of 10 m and a height of 1.5 m above the ground in a clear field (fan side)

- The maximum power input is the mains electricity that must be available in order for the unit to work

- The maximum current absorption refers to the current that will trigger the internal safety devices of the unit. It is the maximum current allowed in the unit..

This value may never be exceeded; it must be used as a reference for determining the size of the power supply line and the related safety devices (refer to the wiring diagram supplied with the units).

RATED TECHNICAL DATA OF HEAT PUMPS

MPI DC - H		008 M	010 M	014	018	023	029
Power supply	V-ph-Hz	230-1-50	230-1-50	400-3N-50	400-3N-50	400-3N-50	400-3N-50
Rated cooling capacity	kW	7,96	10,4	14,0	17,9	22,5	28,5
Total power input	kW	2,62	3,35	4,78	7,63	7,77	12,3
EER (rated capacity)		3,04	3,10	2,93	2,35	2,90	2,32
Total input power with pump	kW	2,8	3,6	5,3	8,2	8,3	12,9
Rated heating capacity	kW	8,89	11,5	15,7	21,6	24,6	33,7
Total power input in heating mode	kW	2,81	3,56	4,96	7,48	7,86	11,7
COP (rated capacity)		3,16	3,23	3,17	2,89	3,13	2,88
Total input power with pump in heating mode	kW	3,0	4,1	5,5	8,0	8,4	12,3
Maximum power input	kW	4,1	5,6	7,1	10,7	10,8	21,9
Maximum absorbed current	A	16	26,6	20,0	22,0	28,5	43,0
Starting current	A	10	10	10	10	10	10
No. of compressors / circuits		1 / 1	1 / 1	1 / 1	1 / 1	1 / 1	1 / 1
Refrigerant charge	kg	2,1	4,1	4,4	4,4	6,0	6,0
High / low pressure switch	bar	42 / 2	42 / 2	42 / 2	42 / 2	42 / 2	42 / 2
No. of axial fans		1	2	2	2	4	4
Air flow rate	m ³ /h	4680	6939	6.939	6.939	11.438	11.438
Water flow rate in cooling mode	l/h	1367	1.789	2.407	3.072	3.861	4.898
Water flow rate in heating mode	l/h	1545	1.974	2.727	3.752	4.273	5.853
Diameter of water connections	"	1 1/4	1 1/4	1 1/4	1 1/4	1 1/4	1 1/4
Water pressure drop (cooling)	kPa	6	22	33	33	34	34
Water pressure drop (heating)	kPa	7	23	36	36	40	40
Available head (cooling)	kPa	93	130	120	120	98	98
Available head (heating)	kPa	95	120	110	110	80	80
Water content, excluding optionals	dm ³	2	3	3	3	5	5
Expansion tank	dm ³	1	5	5	5	5	5
Buffer tank	dm ³	19,5	30	30	30	50	50
Height	mm	758	1250	1250	1250	1300	1300
Length	mm	1241	1220	1220	1220	1565	1565
Depth	mm	582	560	560	560	600	600
Sound power level	dB(A)	68	70	71	71	74	74
Sound pressure level	dB(A)	40	42	43	43	46	46
Transport weight*	kg	144	220	220	220	300	300
Operating weight*	kg	153	240	240	240	347	347

* Weights refer to model with pump and buffer tank

- Cooling capacity: outdoor air temperature 35°C, water temperature 12°C -7°C

- Heating capacity: outdoor air temperature 7°C dry bulb and 6.2°C wet bulb, water temperature 40°C - 45°C

- Sound power measured according to standards ISO 3741 - ISO 3744 and EN 29614-1

- Sound pressure measured at a distance of 10 m and a height of 1.5 m above the ground in a clear field (fan side)

- The maximum power input is the mains electricity that must be available in order for the unit to work

- The maximum current absorption refers to the current that will trigger the internal safety devices of the unit. It is the maximum current allowed in the unit.

This value may never be exceeded; it must be used as a reference for determining the size of the power supply line and the related safety devices (refer to the wiring diagram supplied with the units).

PERFORMA: EFFICIENCY BEYOND EVERY LIMIT

- > R410A
- > OPTIMISED FINNED BLOCK EXCHANGERS
- > QUIET OPERATION
- > HIGH EFFICIENCY
- > EXTENDED OPERATING LIMITS
- > TANDEM CONFIGURATION
- > DYNAMIC SETPOINT
- > OPERATION UNDER PARTIAL LOAD CONDITIONS WITHOUT NEED FOR WATER BUFFER TANK
- > SMART DEFROST SYSTEM
- > IN THE CONFIGURATION WITH AN ELECTRONIC VALVE SUITABLE FOR RADIANT PANEL SYSTEMS.

PERFORMA (MPE) water chillers and heat pumps are designed for outdoor installation in both residential and industrial applications. The range uses R410A refrigerant, which assures high levels of performance with relatively low energy consumption and features 25 models in the chiller and heat pump version, with cooling capacities ranging from 4 to 76 kW and heating capacities from 5 to 85 kW.

BEYOND CONVENTIONAL WORKING LIMITS

The finned block heat exchangers have been optimised for R410A and use 8 mm copper pipes, which permit a better heat exchange and quiet operation of the fans. Their generous sizing guarantees the production of chilled water even with outdoor air temperatures as high as 51°C and all models of the range assure an average energy efficiency ratio (EER) of 2.95 in the cooling mode and heating efficiency (COP) of 3.25, corresponding to the Eurovent Energy Efficiency Class A.

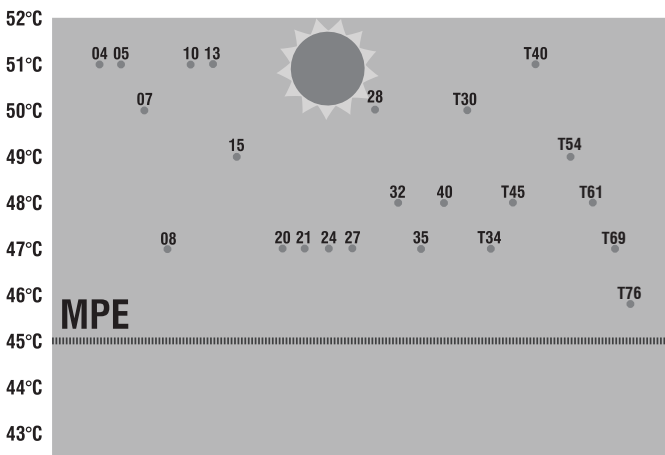

EFFICIENCY IN ALL CONDITIONS

The actual thermal load of an air conditioning system is less than 60% of the rated load capacity 90% of the time; the MPE T version with single-circuit dual compressor answers this demand by offering high efficiency during operation under partial load conditions (ESEER > 4) and also guarantees the unit's operation at the worst temperature conditions. In such conditions the microprocessor controller activates the capacity control mode, doubling the condensing surface available to the single compressor. The axial-type fans with airfoil-shaped blades and 6- and 8-pole motors with electronic speed control (optional) guarantee quiet operation and optimal performance of the unit in all conditions.



SELF-ADAPTIVE CONTROL

The electronic control system allows the setpoint to be adjusted automatically according to the outdoor temperature in order to reduce consumption and broaden the working temperature range. The unit can also function in systems with a low water content, even without the use of a water buffer tank, thanks to the automatic adjustment which limits the number of compressor starts and thus extends the life of the compressors themselves.

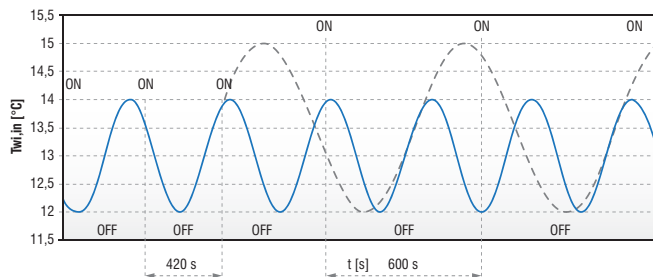

SMART DEFROST SYSTEM

The exclusive defrost system (optional feature available with the advanced controller) can correctly identify an impairment of performance in the outdoor exchanger due to the formation of ice and minimise the process time in relation to normal operation of the unit.

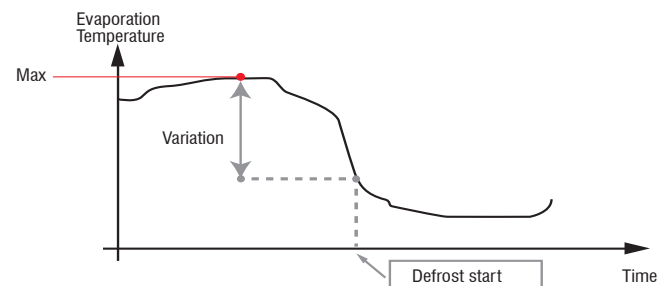

CONSTRUCTIVE COMPONENTS

STRUCTURE

Painted galvanised sheet steel structure (RAL9002) for an attractive look and effective resistance to corrosive agents.

Fastening devices are made of non-oxidizable materials, or carbon steel that has undergone surface-passivating treatments.

The compressor compartment is completely sealed and may be accessed on 3 sides thanks to easy-to-remove panels that greatly simplify maintenance and/or inspection.

Sound insulation, available on request, can further reduce the noise emissions of the unit.

CUSTOMISED HYDRONIC KITS

- High head pump made entirely of stainless steel, already configured for use with mixtures of water and ethylene glycol up to 35% and provided with internal thermal protection.
It is housed in the compressor compartment and is easy to reach thanks to the removable perimeter panels.
- Expansion tank
- Safety valve
- Filling cock (included)
- Automatic vent valve
- Water differential pressure switch and outlet water temperature probe with anti-freeze thermostat function
- Mechanical Y filter supplied as a standard feature on all models to protect the evaporator (included)

COOLING CIRCUIT

- Scroll-type compressor (rotary up to 7 kW) housed in a compartment that can be sound insulated
- Brazed plate heat exchangers made of STAINLESS STEEL and optimised for use with R410A
- Finned block condenser with 8 mm copper piping and aluminium fins, characterised by ample heat exchange surfaces
- Dehydrating filter
- Flow indicator with humidity indicator
- Thermostatic valve with external equalization and integrated MOP function
- Cycle-reversing valve (MPE H)
- Single-acting valves (MPE H)
- Liquid receiver (MPE H)
- High and low pressure switches
- Safety valve
- Schrader valves for checks and/or maintenance
- Refrigerant pressure gauges (optional)

FAN DRIVE ASSEMBLY

Electric fan with 6/8-pole external rotor motor directly keyed to the axial fan, with internal thermal protection on the windings, complete with safety grille and dedicated supporting structure.

The fan is housed in a special compartment having a profile designed to optimise ventilation.

The use of finned block heat exchangers with 8mm diameter pipes reduces pressure drops on the air side, thus significantly improving the noise levels of the units.

The condensation control system continuously and automatically regulates the fan speed, further limiting the noise emissions of the unit during nighttime operation and under partial load conditions.

FINNED BLOCK HEAT EXCHANGER

Made of 8mm diameter copper pipes and aluminium fins, generously sized.

The special engineering of the heat exchangers allows defrost cycles to be carried out at maximum speed in the models with heat pump operation, which brings clear benefits in terms of the integrated efficiency of the whole cycle.

ELECTRONIC MICROPROCESSOR CONTROL

The electronic control enables the complete control of the MPE unit. It can be easily accessed through a polycarbonate flap with IP65 protection rating. The self-adaptive logic enables the unit to operate even in systems where the water content is low, without the use of an inertial buffer tank. By reading the outdoor air temperature, it can automatically change the setpoint to adapt it to the outdoor load conditions or keep the unit running even in the harshest winter conditions.

The basic controller comes complete with the MODBUS protocol and enables an immediate connection to ERGO networks.

Main functions:



- Control over the temperature of water entering the evaporator
- Management of the defrosting function (MPE-H)
- Control of fan speed (optional)
- Complete alarm management
- Dynamic control of the setpoint according to the outdoor air temperature
- Can be connected to an RS485 serial line for supervisory / teleassistance operation
- Option of connecting a remote terminal that duplicates the control functions

Devices controlled:

- Compressor
- Fans
- Cycle-reversing valve (MPE-H)
- Water circulation pump
- Antifreeze heating elements (optional)
- Alarm signalling relay

On request, it is possible to install the advanced controller whose functions extend to:

- LAN networks
- Smart Defrost System

ELECTRIC CONTROL BOARD

The electric control board is constructed and wired in accordance with EEC Directive 73/23, Directive 89/336 on electromagnetic compatibility and related standards. Made of steel sheet, it is also protected by the enclosing panels of the unit.

OPTIONS

- Incorporable hydronic kits
- Condensation control
- Low noise execution
- Refrigerant pressure gauges
- Antifreeze heating elements on the water circuit
- Electronic thermostatic valve
- Heat recovery (chiller)
- Special exchangers (hydrophilic treatment, copper-copper, cataphoresis, anti-corrosion)

ACCESSORIES AVAILABLE

- Remote control boards
- Base vibration dampers
- Metal grilles to protect exchangers

MPE-C		004 M	005 M	007 M	008 M	008	010 M	010	013	015	018	020	024	027	028
Power supply	V-ph-Hz	230-1-50	230-1-50	230-1-50	230-1-50	400-3-50	230-1-50	400-3-50	400-3-50	400-3-50	400-3-50	400-3-50	400-3-50	400-3-50	400-3-50
Cooling capacity	kW	4.11	5.10	6.66	8.40	8.40	9.25	9.25	12.90	14.98	17.20	19.61	23.80	26.60	28.10
Total power input	kW	1.35	1.70	2.26	3.35	3.09	3.22	3.22	4.16	5.16	6.32	7.12	8.10	9.33	8.65
EER		3.06	3.01	2.95	2.51	2.72	2.87	2.87	3.10	2.90	2.72	2.75	2.94	2.85	3.25
ESEER		3.54	3.39	3.32	2.98	3.36	3.38	3.38	3.69	3.53	3.30	3.21	3.42	3.36	3.77
Total input power with pump	kW	1.49	1.84	2.40	3.49	3.23	3.59	3.59	4.53	5.53	6.69	7.49	8.47	9.70	9.20
Maximum power input	kW	2.0	2.3	3.0	5.0	5.0	5.1	7.2	8.9	10.5	12.5	13.6	14.5	18.0	18.3
Maximum absorbed current	A	9.8	11.6	15.3	24.2	9.2	26.3	14.4	17.4	20.0	24.3	26.2	27.6	33.6	35.5
Starting current	A	38	44	63	98	49	99	50	65	68	75	104	158	132	133
No. of compressors / circuits		1 / 1	1 / 1	1 / 1	1 / 1	1 / 1	1 / 1	1 / 1	1 / 1	1 / 1	1 / 1	1 / 1	1 / 1	1 / 1	1 / 1
Refrigerant charge	kg	1.47	1.48	2.04	2.09	2.09	2.87	2.87	3.99	4.11	3.67	4.23	5.8	6.0	7.5
High / low pressure switch	bar	2 / 42	2 / 42	2 / 42	2 / 42	2 / 42	2 / 42	2 / 42	2 / 42	2 / 42	2 / 42	2 / 42	2 / 42	2 / 42	2 / 42
No. of axial fans		1	1	1	1	1	2	2	2	2	4	4	4	4	2
Air flow rate	m	3,635	3,635	3,406	3,406	3,406	7,385	7,385	6,939	6,939	9,990	9,990	9,307	9,307	16,276
Water flow rate	l/h	707	877	1,146	1,445	1,445	1,591	1,591	2,219	2,577	2,958	3,373	4,094	4,575	4,833
Diameter of water connections	inches	1	1	1	1	1	1 1/4	1 1/4	1 1/4	1 1/4	1 1/4	1 1/4	1 1/4	1 1/4	1 1/4
Pressure drop, water side	kPa	2	4	6	6	6	34	34	61	38	51	51	49	34	40
Available head	kPa	63	61	57	53	53	116	116	83	103	129	123	116	124	143
Water content, excluding optionals	dm	1.5	1.5	1.5	1.5	1.5	3.0	3.0	3.0	3.0	4.0	4.0	4.0	4.0	5.5
Expansion tank	dm	1	1	1	1	1	5	5	5	5	5	5	5	5	8
Buffer tank	dm	20	20	20	20	20	30	30	30	30	50	50	50	50	125
Height	mm	758	758	758	758	758	1250	1250	1250	1250	1300	1300	1300	1300	1485
Length	mm	960	960	960	960	960	1220	1220	1220	1220	1565	1565	1565	1565	1990
Depth	mm	450	450	450	450	450	560	560	560	560	600	600	600	600	950
Sound power level	dB(A)	66	66	67	67	67	69	69	69	69	71	71	72	72	73
Sound pressure level	dB(A)	38	38	39	39	39	41	41	41	41	43	43	44	44	45
Transport weight*	kg	98	100	107	110	110	202	202	209	209	260	260	280	285	370
Operating weight*	kg	92.3	94.3	101.3	104.3	104.3	227.5	227.5	234.5	234.5	306.3	296.3	327.3	332.3	492
MPE-C		032	035	040	054	066		T30	T34	T40	T45	T54	T61	T69	T76
Power supply	V-ph-Hz	400-3-50	400-3-50	400-3-50	400-3-50	400-3-50		400-3-50	400-3-50	400-3-50	400-3-50	400-3N-50	400-3N-50	400-3N-50	400-3N-50
Cooling capacity	kW	31.52	35.00	39.67	51.4	66.1		30.00	34.05	39.57	44.55	54.6	61.9	69.8	76.1
Total power input	kW	10.06	11.51	12.77	17.8	24.1		10.43	12.59	13.64	16.38	18.3	21.2	23.6	27.5
EER		3.13	3.04	3.11	3.04	2.74		2.88	2.70	2.90	2.72	2.98	2.92	2.96	2.77
ESEER		3.63	3.61	3.68	3.6	3.3		4.17	4.11	4.15	4.04	4.03	4.01	4.18	4.16
Total input power with pump	kW	10.61	12.06	13.32	18.7	25		10.98	13.14	14.19	16.93	19.6	22.5	24.9	28.8
Maximum power input	kW	18.9	21.8	22.4	22.7	23.3		20.9	24.4	26.6	30.8	27	29.9	32.3	39.4
Maximum absorbed current	A	36.5	41.5	42.5	45.2	46.2		39.9	45.9	49.7	56.7	48	53	57	69
Starting current	A	166	161	163	163	165		86	96	127	130	177	187	202	229
No. of compressors / circuits		1 / 1	1 / 1	1 / 1	1 / 1	1 / 1		2 / 1	2 / 1	2 / 1	2 / 1	2 / 1	2 / 1	2 / 1	2 / 1
Refrigerant charge	kg	7.5	7.8	10.8	13	15.0		7.8	7.8	10.9	10.9	11	11	16	16
High / low pressure switch	bar	2 / 42	2 / 42	2 / 42	2 / 42	2 / 42		2 / 42	2 / 42	2 / 42	2 / 42	2 / 42	2 / 42	2 / 42	2 / 42
No. of axial fans		2	2	2	2	2		2	2	2	2	4	4	4	4
Air flow rate	m	16,276	16,276	15,776	20000	20000		16,276	16,276	15,776	15,776	24930	24930	24354	24354
Water flow rate	l/h	5,421	6,021	6,823	9305	11376		5,160	5,857	6,806	7,663	9391	10647	12006	13089
Diameter of water connections	inches	1 1/4	1 1/4	1 1/4	1 1/4	1 1/4		1 1/4	1 1/4	1 1/4	1 1/4	2	2	2	2
Pressure drop, water side	kPa	51	41	43	60	60		30.01	38	45	57	56	69	55	64
Available head	kPa	126	130	119	110	95		150	134	117	97	138	120	128	114
Water content, excluding optionals	dm	5.5	5.5	5.5	7	8		5.5	5.5	5.5	5.5	7	8	11	12
Expansion tank	dm	8	8	8	8	8		8	8	8	8	8	8	8	8
Buffer tank	dm	125	125	125	125	125		125	125	125	125	125	125	125	125
Height	mm	1485	1485	1485	1485	1485		1485	1485	1485	1485	1735	1735	1735	1735
Length	mm	1990	1990	1990	1990	1990		1990	1990	1990	1990	2091	2091	2091	2091
Depth	mm	950	950	950	950	950		950	950	950	950	1183	1183	1183	1183
Sound power level	dB(A)	73	73	75	78	78		72	72	72	72	81	81	81	81
Sound pressure level	dB(A)	45	45	47	50	50		44	44	44	44	53	53	53	53
Transport weight*	kg	370	390	390	500	530		410	410	430	430	652	692	757	837
Operating weight*	kg	492	513	513	620	650		532	533	553	553	777	817	882	962

* Weights refer to model with pump and buffer tank
 - Cooling capacity: outdoor air temperature 35°C, water temperature 12°C -7°C
 - Sound pressure measured at a distance of 10 m and a height of 1.5 m above the ground in a clear field (fan side).

MPE-H		004 M	005 M	007 M	008 M	008	010 M	010	013	015	018	020	024	027	028
Power supply	V-ph-Hz	230-1-50	230-1-50	230-1-50	230-1-50	400-3-50	230-1-50	400-3-50	400-3-50	400-3-50	400-3-50	400-3-50	400-3-50	400-3-50	400-3-50
Cooling capacity	kW	4.03	5.00	6.53	8.23	8.23	9.07	9.07	12.64	14.68	16.86	19.22	23.32	26.07	27.54
Total power input	kW	1.35	1.70	2.26	3.35	3.09	3.22	3.22	4.16	5.16	6.32	7.12	8.10	9.33	8.65
EER		2.99	2.95	2.89	2.46	2.67	2.82	2.82	3.04	2.85	2.67	2.70	2.88	2.79	3.18
ESEER		3.47	3.32	3.26	2.92	3.29	3.31	3.31	3.62	3.46	3.23	3.15	3.35	3.29	3.70
Total input power with pump	kW	1.49	1.84	2.40	3.49	3.23	3.59	3.59	4.53	5.53	6.69	7.49	8.47	9.70	9.20
Heating capacity	kW	4.72	5.86	7.77	10.21	9.95	10.87	10.87	15.09	17.60	20.03	22.96	27.15	29.98	31.37
Total power input in heating mode	kW	1.46	1.81	2.41	3.59	3.25	3.62	3.62	4.70	5.49	6.63	7.16	8.11	8.89	9.14
COP		3.24	3.25	3.23	2.85	3.07	3.00	3.00	3.21	3.02	3.02	3.21	3.35	3.37	3.43
Total input power with pump in heating mode	kW	1.60	1.95	2.55	3.73	3.39	3.99	3.99	5.07	5.86	7.00	7.53	8.48	9.26	9.69
Maximum power input	kW	2.0	2.3	3.0	5.0	5.0	5.1	7.2	8.9	10.5	12.5	13.6	14.5	18.0	18.3
Maximum absorbed current	A	9.80	11.60	15.30	24.20	9.20	26.30	14.40	17.40	20.00	24.30	26.20	27.6	33.60	35.50
Starting current	A	38	44	63	98	49	99	50	65	68	75	104	158	132	133
No. of compressors / circuits		1 / 1	1 / 1	1 / 1	1 / 1	1 / 1	1 / 1	1 / 1	1 / 1	1 / 1	1 / 1	1 / 1	1 / 1	1 / 1	1 / 1
Refrigerant charge	kg	1.47	1.48	2.04	2.09	2.09	2.87	2.87	3.99	4.11	3.67	4.23	5.8	6.0	7.5
High / low pressure switch	bar	2 / 42	2 / 42	2 / 42	2 / 42	2 / 42	2 / 42	2 / 42	2 / 42	2 / 42	2 / 42	2 / 42	2 / 42	2 / 42	2 / 42
No. of axial fans		1	1	1	1	1	2	2	2	2	4	4	4	4	2
Air flow rate	m	3,635	3,635	3,406	3,406	3,406	7,385	7,385	6,939	6,939	9,990	9,990	9,307	9,307	16,276
Flow rate cooling only	l/h	707	877	1,146	1,445	1,445	1,591	1,591	2,219	2,577	2,958	3,373	4,094	4,575	4,833
Water flow rate heat pump mode	l/h	811	1,008	1,337	1,755	1,711	1,869	1,869	2,595	3,027	3,445	3,949	4,670	5,156	5,396
Diameter of water connections	"	1	1	1	1	1	1 1/4	1 1/4	1 1/4	1 1/4	1 1/4	1 1/4	1 1/4	1 1/4	1 1/4
Water pressure drop (cooling)	kPa	2	4	6	6	6	34	34	61	38	51	51	49	34	40
Water pressure drop (heating)	kPa	3	4	8	8	8	45	45	83	51	69	69	62	43	49
Available head (cooling)	kPa	63	61	57	53	53	116	116	83	103	129	123	116	124	143
Available head heat pump	kPa	62	59	53	48	48	102	102	57	86	104	97	95	107	128
Water content, excluding optionals	dm	1.5	1.5	1.5	1.5	1.5	3.0	3.0	3.0	3.0	4.0	4.0	4.0	4.0	5.5
Expansion tank	dm	1	1	1	1	1	5	5	5	5	5	5	5	5	8
Buffer tank	dm	n.a.	n.a.	n.a.	n.a.	n.a.	30	30	30	30	50	50	50	50	125
Height	mm	758	758	758	758	758	1250	1250	1250	1250	1300	1300	1300	1300	1485
Length	mm	960	960	960	960	960	1220	1220	1220	1220	1565	1565	1565	1565	1990
Depth	mm	450	450	450	450	450	560	560	560	560	600	600	600	600	950
Sound power level	dB(A)	66	66	67	67	67	69	69	69	69	71	71	72	72	73
Sound pressure level	dB(A)	38	38	39	39	39	41	41	41	41	43	43	44	44	45
Transport weight*	kg	103	105	111.7	115	115	212	212	219	220	273	273	295	300	400
Operating weight*	kg	97.3	99.3	106	109.3	109.3	237.5	237.5	244.5	245.5	319.3	309.3	342.3	347.3	522
MPE-H		032	035	040	054	066		T30	T34	T40	T45	T54	T61	T69	T76
Power supply	V-ph-Hz	400-3-50	400-3-50	400-3-50	400-3-50	400-3-50		400-3-50	400-3-50	400-3-50	400-3-50	400-3N-50	400-3N-50	400-3N-50	400-3N-50
Cooling capacity	kW	30.89	34.30	38.88	52.00	62.80		29.40	33.37	38.78	43.66	53.5	60.7	68.5	74.6
Total power input	kW	10.06	11.51	12.77	17.80	24.10		10.43	12.59	13.64	16.38	18.30	21.20	23.60	27.50
EER		3.07	2.98	3.04	2.92	2.60		2.82	2.65	2.84	2.67	2.91	2.86	2.9	2.71
ESEER		3.56	3.54	3.61	3.50	3.20		4.09	4.03	4.06	3.96	4.01	3.99	4.16	4.15
Total input power with pump	kW	10.61	12.06	13.32	18.70	25.00		10.98	13.14	14.19	16.93	19.6	22.5	24.9	28.8
Heating capacity	kW	35.58	39.28	45.17	60.80	75.30		34.51	39.41	46.49	52.72	59.90	67.50	77.00	84.76
Total power input in heating mode	kW	10.42	11.57	13.14	18.30	23.10		10.86	12.80	13.97	16.26	18.50	21.50	23.40	26.82
COP		3.41	3.39	3.44	3.32	3.26		3.18	3.08	3.33	3.24	3.24	3.14	3.29	3.16
Total input power with pump in heating mode	kW	10.97	12.12	13.69	19.20	24.00		11.41	13.35	14.52	16.81	19.76	22.76	24.66	28.08
Maximum power input	kW	18.9	21.8	22.4	22.70	23.30		20.9	24.4	26.6	30.8	27.0	29.9	32.3	39.4
Maximum absorbed current	A	36.50	41.50	42.50	45.20	46.20		39.9	45.9	49.70	56.70	48	53	57	69
Starting current	A	166	161	163	163	165		86	96	127	130	177	187	202	229
No. of compressors / circuits		1 / 1	1 / 1	1 / 1	1 / 1	1 / 1		2 / 1	2 / 1	2 / 1	2 / 1	2 / 1	2 / 1	2 / 1	2 / 1
Refrigerant charge	kg	7.5	7.8	10.8	13	16.0		7.8	7.8	10.9	10.9	13	13	19.5	19.5
High / low pressure switch	bar	2 / 42	2 / 42	2 / 42	2 / 42	2 / 42		2 / 42	2 / 42	2 / 42	2 / 42	2 / 42	2 / 42	2 / 42	2 / 42
No. of axial fans		2	2	2	2	2		2	2	2	2	4	4	4	4
Air flow rate	m	16,276	16,276	15,776	20000	20000		16,276	16,276	15,776	15,776	24930	24930	24354	24354
Flow rate cooling only	l/h	5,421	6,021	6,823	8944	10802		5,160	5,857	6,806	7,663	9202	10440	11782	12831
Water flow rate heat pump mode	l/h	6,120	6,756	7,769	10456	12953		5,935	6,779	7,996	9,067	10303	11610	13244	14579
Diameter of water connections	"	1 1/4	1 1/4	1 1/4	1 1/4	1 1/4		1 1/4	1 1/4	1 1/4	1 1/4	2	2	2	2
Water pressure drop (cooling)	kPa	51	41	43	60	60		30	38	45	57	56	69	55	64
Water pressure drop (heating)	kPa	63	50	54	80	80		39	51	57	73	60	77	59	71
Available head (cooling)	kPa	126	130	119	112	99		150	134	117	97	138	120	128	114
Available head heat pump	kPa	107	113	99	80	61		133	112	93	67	130	120	110	100
Water content, excluding optionals	dm	5.5	5.5	5.5	7	8		5.5	5.5	5.5	5.5	7	8	11	12
Expansion tank	dm	8	8	8	8	8		8	8	8	8	8	8	8	8
Buffer tank	dm	125	125	125	125	125		125	125	125	125	125	125	125	125
Height	mm	1485	1485	1485	1485	1485		1485	1485	1485	1485	1735	1735	1735	1735
Length	mm	1990	1990	1990	1990	1990		1990	1990	1990	1990	2091	2091	2091	2091
Depth	mm	950	950	950	950	950		950	950	950	950	1183	1183	1183	1183
Sound power level	dB(A)	73	73	75	78	78		72	72	72	72	81	81	81	81
Sound pressure level	dB(A)	45	45	47	50	50		44	44	44	44	53	53	53	53
Transport weight*	kg	400	420	420	530	560		430	430	430	450	657	697	762	842
Operating weight*	kg	522	543	543	650	680		552	552	553	573	782	822	887	967

* Weights refer to model with pump and buffer tank

- Cooling capacity: outdoor air temperature 35°C, water temperature 12°C -7°C

- Cooling capacity: outdoor air temperature 7°C dry bulb and 6.2°C wet bulb, water temperature 40°C/45°C

- Sound pressure measured at a distance of 10 m and a height of 1.5 m above the ground in a clear field (fan side).

MCC AIR-COOLED WATER CHILLERS WITH CENTRIFUGAL FANS

The package air-cooled water chillers and cycle reversing heat pumps of the **MCC** series are designed to be installed indoors as part of residential or commercial duct systems.

Designed and developed for R410A refrigerant, the MCC series achieves exceptional levels of energy efficiency thanks to the optimisation of the heat exchangers in terms of plate type and distribution.

The design philosophy places a priority on compactness, "plug & play" solutions and easy access to all the components: the logic of the **PLUG&PLAY PLUMBING**, already in the **DNA** of the whole water line, is combined here with the innovative **PLUG&PLAY VENTILATION** philosophy. The continuously modulating adaptive control of the fan flow rate (pressostatic condensation control as a standard feature of all models making up the range) drastically reduces installation times.

PLUG & PLAY VENTILATION SYSTEM:

Automatic air flow adaptation based on:

- pressure drops in channels
- intake air temperature

A standard feature of all units is pressostatic condensation control which modulates, by means of a phase cut device, the number of fan revolutions depending on the pressure drops on the air side and the inlet air temperature. Air delivery can be configured vertically or horizontally (optional).

PLUG & PLAY WATER SYSTEM

To enable immediate application of MCC to the system, 3 different hydronic kits are available:

- B version: units with evaporator only.
- P version: units equipped with evaporator, electric pump and expansion tank.
- S version: units equipped with evaporator, electric pump, expansion tank and inertial buffer tank.
- **Mechanical Y filter (COMPULSORY) supplied as a standard feature on all models to protect the evaporator.**

SIMPLIFIED MAINTENANCE

Direct coupling of the centrifugal fans to the electric motor without any pulleys or belts.

The technical / cooling compartment is completely separated from the fan compartment so that checks can be performed while the chiller is operating. Controller accessible from outside the unit.

MICROPROCESSOR CONTROL AND REGULATION

New generation, allows connection with ERGO 

Possibility of connecting / changing the set-point of the unit based on the outdoor air temperature read by an ambient probe (optional).

The series features 10 models in cooling only version, and cooling capacity ranging from 6 to 37 kW, and 10 models with reversible heat pump, and heating capacity ranging from 6 to 41 kW.



ACCESSORIES AVAILABLE

- Refrigerant pressure gauges
- Antifreeze heating elements on the water circuit
- Electronic thermostatic valve
- Heat recovery (cooling only models)
- Special heat exchangers (copper-copper, cataphoresis, Blygold)
- Remote microprocessor or simplified control
- Base vibration dampers
- Metal grilles to protect exchangers
- Outlet connectors

WATER CHILLERS RATED TECHNICAL DATA							
MCC-C		06M	07M	09M	06	07	09
Power supply	V-ph-Hz	230-1-50			400-3-50		
Cooling capacity	kW	5,70	6,90	9,20	5,70	6,95	9,25
MCC CB Total power input	kW	2,61	3,18	4,83	2,58	3,04	4,63
MCC CP CS Total power input	kW	2,75	3,32	5,20	2,72	3,18	5,00
Maximum power input	kW	4	5	7	4	5	7
Maximum current absorption	A	17,1	19,1	33,6	7,5	9,5	17,4
Starting absorbed current	A	61,6	82,6	100,2	32,6	35,6	51,2
n° of scroll compressors / circuits		1/1	1/1	1/1	1/1	1/1	1/1
n° of axial fan		1	1	1	1	1	1
Air flow	m³/h	2.500	2.500	5.500	2.500	2.500	5.500
ASEP	Pa	91	85	140	91	85	135
Water flow	l/s	0,273	0,329	0,439	0,272	0,331	0,442
Water side pressure drop	kPa	4	4	36	4	5	36
Available pressure head	kPa	57	55	155	57	55	155
Diameter of hydraulic connections	"	1	1	1 1/4	1	1	1 1/4
Water content escluding optionals	dm³	2,5	2,8	3,3	2,5	2,8	3,3
Expansion tank	dm³	1	1	5	1	1	5
Buffer tank	dm³	20	20	36	20	20	36
Height	mm	1.000	1.000	1.160	1.000	1.000	1.160
Length	mm	1.050	1.050	1.250	1.050	1.050	1.250
Width	mm	600	600	730	600	600	730
Sound power level	dB(A)	70	70	78	70	70	78
Sound pressure level	dB(A)	42	42	50	42	42	50
Transport weight *	kg	160	165	220	160	165	220
Operating weight *	kg	168	178	239	168	178	239

WATER CHILLERS RATED TECHNICAL DATA								
MCC-C		12	15	18	22	25	33	37
Power supply	V-ph-Hz	400-3-50						
Cooling capacity	kW	12,00	14,60	18,00	22,30	25,50	33,10	36,70
MCC CB Total power input	kW	5,73	6,43	7,53	8,93	12,05	14,85	16,25
MCC CP CS Total power input	kW	6,10	6,80	7,90	9,30	12,60	15,40	16,80
Maximum power input	kW	9	9	11	13	17	19	21
Maximum current absorption	A	19,4	20,4	23,2	25,2	28,4	34,6	38,2
Starting absorbed current	A	67,2	77,2	104,2	114,2	134,6	162,6	199,6
n° of scroll compressors / circuits		1/1	1/1	1/1	1/1	1/1	1/1	1/1
n° of axial fan		1	1	1	1	2	2	2
Air flow	m³/h	5.500	5.500	6.500	6.500	11.000	13.000	13.000
ASEP	Pa	130	120	120	110	125	95	90
Water flow	l/s	0,573	0,698	0,860	1,065	1,218	1,582	1,753
Water side pressure drop	kPa	39	56	38	45	48	41	38
Available pressure head	kPa	148	125	136	118	123	123	121
Diameter of hydraulic connections	"	1 1/4	1 1/4	1 1/4	1 1/4	1 1/4	1 1/4	1 1/4
Water content escluding optionals	dm³	4	4	4	5	6	7	8
Expansion tank	dm³	5	5	5	5	8	8	8
Buffer tank	dm³	36	36	96	96	155	155	155
Height	mm	1.160	1.160	1.210	1.210	1.400	1.400	1.400
Length	mm	1.250	1.250	1.650	1.650	2.250	2.250	2.250
Width	mm	730	730	800	800	800	800	800
Sound power level	dB(A)	78	78	79	79	80	82	82
Sound pressure level	dB(A)	50	50	51	51	52	54	54
Transport weight *	kg	228	240	295	301	405	430	440
Operating weight *	kg	248	260	375	381	546	572	583

* Weights refer to model with pump and buffer tank

- Cooling capacity: outdoor air temperature 35°C, water temperature 12°C 7°C - Sound power measured according to standards ISO 3741 - ISO 3744 and EN 29614-1
 - Sound pressure measured at a distance of 10 m and a height of 1.5 m above the ground in a clear field (fan side).

HEAT PUMPS RATED TECHNICAL DATA							
MCC-H		06M	07M	09M	06	07	09
Power supply	V-ph-Hz	230-1-50			400-3-50		
Cooling capacity	kW	5,6	6,75	9	5,6	6,8	9,1
MCC HB Cooling power input	kW	2,61	3,18	4,83	2,58	3,04	4,63
MCC HP - HS Cooling power input	kW	2,75	3,32	5,2	2,72	3,18	5
Heating capacity	kW	6,4	7,75	10,2	6,4	7,65	9,95
MCC HB Heating power input	kW	2,86	3,38	5,2	2,94	3,23	4,9
MCC HP - HS Heating power input	kW	3	3,52	5,57	3,08	3,37	5,27
Maximum power input	kW	4	5	7	4	5	7
Maximum current absorption	A	17,1	19,1	33,6	7,5	9,5	17,4
Starting absorbed current	A	61,56	82,6	100,2	32,6	35,6	51,2
n° of scroll compressor / circuits		1/1	1/1	1/1	1/1	1/1	1/1
n° of axial fan		1	1	1	1	1	1
Air flow	m ³ /h	2.500	2.500	5.500	2.500	2.500	5.500
AESP	Pa	91	85	140	91	85	135
Water flow in cooling mode	l/s	0,267	0,323	0,431	0,267	0,325	0,433
Water flow in heat pump	l/s	0,306	0,369	0,488	0,308	0,365	0,477
Water pressure drop (cooling)	kPa	4	4,3	34,6	4	4,3	34,9
Water pressure drop (heating)	kPa	5,1	5,4	42	5,1	5,4	42
Available pressure head (cooling)	kPa	57,4	55,5	156,7	57,4	55,4	156,4
Available pressure head (heating)	kPa	55,2	52,9	145,4	55	53,2	147,7
Diameter of hydraulic connections	"	1	1	1 1/4	1	1	1 1/4
Water content escluding optionals	dm ³	2,5	2,8	3,3	2,5	2,8	3,3
Expansion tank	dm ³	1	1	5	1	1	5
Buffer tank	dm ³	20	20	36	20	20	36
Height	mm	1.000	1.000	1.160	1.000	1.000	1.160
Length	mm	1.050	1.050	1.250	1.050	1.050	1.250
Width	mm	600	600	730	600	600	730
Sound power level	dB(A)	70	70	78	70	70	78
Sound pressure level	dB(A)	42	42	50	42	42	50
Transport weight *	kg	170	180	240	170	180	240
Operating weight *	kg	173	183	260	173	183	260

HEAT PUMPS RATED TECHNICAL DATA								
MCC-H		12	15	18	22	25	33	37
Power supply	V-ph-Hz	400-3-50						
Cooling capacity	kW	11,70	14,30	17,60	21,80	25,00	32,40	35,90
MCC HB Cooling power input	kW	5,73	6,43	7,53	8,93	12,05	14,85	16,25
MCC HP - HS Cooling power input	kW	6,10	6,80	7,90	9,30	12,60	15,40	16,80
Heating capacity	kW	13,10	15,50	19,20	23,80	28,20	36,36	40,56
MCC HB Heating power input	kW	6,10	6,72	7,73	9,23	12,35	15,25	16,75
MCC HP - HS Heating power input	kW	6,47	7,09	8,12	9,57	12,85	15,75	17,25
Maximum power input	kW	9	9	11	13	17	19	21
Maximum current absorption	A	19,4	20,4	23,2	25,2	28,4	34,6	38,2
Starting absorbed current	A	67,2	77,2	104,2	114,2	134,6	162,6	199,6
n° of scroll compressor / circuits		1/1	1/1	1/1	1/1	1/1	1/1	1/1
n° of axial fan		1	1	1	1	2	2	2
Air flow	m ³ /h	5.500	5.500	6.500	6.500	11.000	13.000	13.000
AESP	Pa	130	120	120	110	125	95	90
Water flow in cooling mode	l/s	0,561	0,684	0,843	1,043	1,194	1,550	1,715
Water flow in heat pump	l/s	0,626	0,743	0,920	1,138	1,349	1,729	1,930
Water pressure drop (cooling)	kPa	37	54	37	44	46	39	37
Water pressure drop (heating)	kPa	46	63	44	51	58	48	46
Available pressure head (cooling)	kPa	150	128	138	121	125	125	124
Available pressure head (heating)	kPa	139	116	128	107	111	112	109
Diameter of hydraulic connections	"	1 1/4	1 1/4	1 1/4	1 1/4	1 1/4	1 1/4	1 1/4
Water content escluding optionals	dm ³	4	4	4	5	6	7	8
Expansion tank	dm ³	5	5	5	5	8	8	8
Buffer tank	dm ³	36	36	96	96	155	155	155
Height	mm	1.160	1.160	1.210	1.210	1.400	1.400	1.400
Length	mm	1.250	1.250	1.650	1.650	2.250	2.250	2.250
Width	mm	730	730	800	800	800	800	800
Sound power level	dB(A)	78	78	79	79	80	82	82
Sound pressure level	dB(A)	50	50	51	51	52	54	54
Transport weight *	kg	245	250	310	342	450	475	485
Operating weight *	kg	265	270	388	436	601	627	638

* Weights refer to model with pump and buffer tank
 - Cooling capacity: outdoor air temperature 35°C, water temperature 12-7°C
 - Heating capacity: outdoor air temperature 7°C dry bulb and 6.2°C wet bulb, water temperature 40°C/45°C

- Sound power measured according to standards ISO 3741 - ISO 3744 and EN 29614-1
 - Sound pressure measured at a distance of 10 m and a height of 1.5 m above the ground in a clear field (fan side)

MCW WATER-COOLED CHILLERS AND HEAT PUMPS

MCW chillers, heat pumps and motor-driven evaporating units are designed for residential and light-duty commercial applications and in some cases for industrial applications with 24 h/day operation. **MCW** chillers are available in a completely enclosed version for a low noise operation, thanks to the use of scroll-type compressors.

Thanks to their compact dimensions, the pre-assembled hydraulic components and their attractive design, they are suitable for a variety of environments and do not need to be installed in dedicated rooms.

The design philosophy has favoured the development of units having a reduced height with water or cooling (**MCR**) connections from above and pre-assembled piping system, which reduce installation time and costs and the need for technical space.

The large number of sizes making up the series and the available accessories allow a broad range of possible configurations, which make the **MCW** series an ideal solution for speeding up installation on the building site.

Only top quality components are used for the cooling, hydraulic and electric systems guaranteeing high technical level of the **MCW** chillers in terms of efficiency, reliability and reduced noise levels.

All the units are available in single circuit configurations.

The mechanical Y filter is COMPULSORY on all models to protect the heat exchangers (user side, dissipator side).

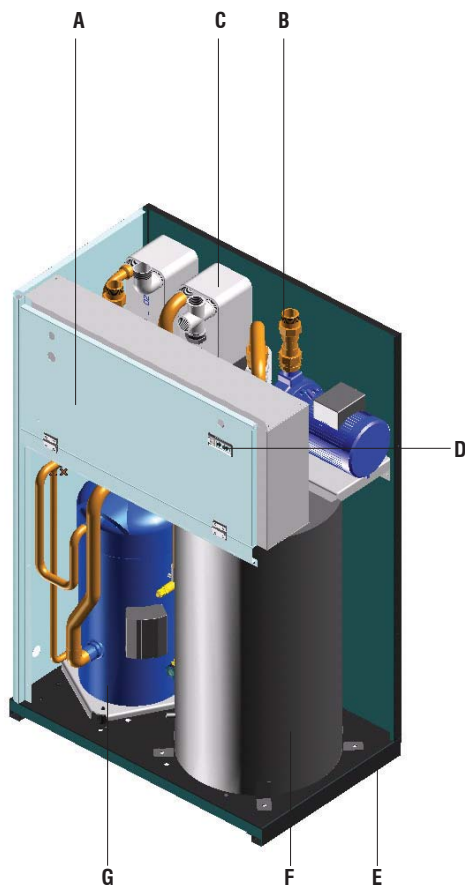

- A** The electric control board is constructed and wired in accordance with EEC Directive 72/23, Directive 89/336 on electromagnetic compatibility and related standards.
- B** All the units have plumbing connections upwards, thus contributing to a considerable reduction of the minimum clearance for installation and maintenance operations. A water flow control device is available upon request. In addition to this device an outlet water temperature sensor is available, that performs the function of an antifreeze thermostat.
- C** Only heat exchangers with stainless steel braze-welded plates are used.
- D** Microprocessor control; the Basic version featured on standard models is a μ Chiller controller.
- E** Painted galvanised sheet steel supporting base The enclosing panels made of galvanised sheet steel coated with epoxy polyester powder (RAL 7035) contribute to an attractive design suitable for installations in residential environments.
- F** On request the units can be equipped with an electric pump and buffer tank incorporated in the unit itself; the tank is installed at the plumbing outlet on the user side.
- G** Only Scroll-type compressors are used in all **MCW** units.

RATED TECHNICAL DATA of MCW C water chillers								
MCW - CS / CL		005 M	005	007 M	007	010 M	010	012
Cooling capacity	kW	5,55	5,50	7,04	7,00	9,90	9,90	12,20
Rated input power	kW	1,32	1,30	1,74	1,70	2,34	2,30	2,75
Rated current absorption	A	6,26	3,17	8,27	3,47	11,21	4,71	6,70
Power supply	V-ph-Hz	230-1-50	400-3-50 + N	230-1-50	400-3-50 + N	230-1-50	400-3-50 + N	400-3-50 + N
Maximum absorbed current	A	12	4,2	15	5,1	23,1	7	10
Inrush current	A	47	24	61	32	100	46	50
Evaporator water flow rate	l/h	954	946	1.211	1.203	1.703	1.704	2.098
Pressure drops, evaporator side	kPa	28	27	31	31	27	27	31
Condenser water flow rate	l/h	390	386	498	494	695	693	849
Pressure drops - condenser side	kPa	4	4	6	6	5	5	7
Scroll compressors / cooling circuits	No.	1 / 1	1 / 1	1 / 1	1 / 1	1 / 1	1 / 1	1 / 1
Water content in user section	dm ³	2,1	2,1	2,1	2,1	2,6	2,6	2,6
Pump available head (option)	kPa	77	78	68	69	60	60	124
Pump electrical output (option)	kW	0,25	0,25	0,25	0,25	0,25	0,25	0,33
Buffer tank (option)	dm ³	47	47	47	47	47	47	92
Water connections GAS type		1"	1"	1"	1"	1"	1"	1" 1/2
Height	mm	830	830	830	830	830	830	1.270
Length	mm	705	705	705	705	705	705	812
Depth	mm	453	453	453	453	453	453	508
Standard unit weight	kg	103	103	106	106	108	108	118
MCW-CS: Sound power level	dB(A)	55	55	55	55	59	59	61
MCW-CL: Sound power level	dB(A)	53	53	53	53	57	57	59

RATED TECHNICAL DATA of MCW C water chillers								
MCW - CS / CL		015	018	020	022	027	031	039
Cooling capacity	kW	14,90	17,80	20,20	21,90	26,90	31,20	38,70
Rated input power	kW	3,40	3,95	4,40	4,90	6,30	7,20	8,90
Rated current absorption	A	8,58	9,39	11,22	12,04	15,56	18,12	21,10
Power supply	V-ph-Hz	400-3-50 + N						
Maximum absorbed current	A	13	14	16	17	20	29	32
Inrush current	A	66	74	101	98	130	130	135
Evaporator water flow rate	l/h	2.562	3.062	3.458	3.766	4.627	5.367	6.656
Pressure drops, evaporator side	kPa	27	30	26	29	26	29	28
Condenser water flow rate	l/h	1.039	1.235	1.392	1.522	1.885	2.181	2.703
Pressure drops - condenser side	kPa	4	6	5	6	5	7	7
Scroll compressors / cooling circuits	No.	1 / 1	1 / 1	1 / 1	1 / 1	1 / 1	1 / 1	1 / 1
Water content in user section	dm ³	3,1	3,1	3,6	3,6	3,9	4,3	4,6
Pump available head (option)	kPa	113	92	135	125	106	82	129
Pump electrical output (option)	kW	0,33	0,33	0,45	0,45	0,45	0,45	0,75
Buffer tank (option)	dm ³	92	92	92	92	92	92	92
Water connections GAS type		1" 1/2	1" 1/2	1" 1/2	1" 1/2	1" 1/2	1" 1/2	1" 1/2
Height	mm	1.270	1.270	1.270	1.270	1.270	1.270	1.270
Length	mm	812	812	812	812	812	812	812
Depth	mm	508	508	508	508	508	508	508
Standard unit weight	kg	121	125	167	203	210	219	233
MCW-CS: Sound power level	dB(A)	61	61	61	62	62	65	65
MCW-CL: Sound power level	dB(A)	59	59	60	60	60	63	63

Cooling capacity refers to the following conditions: water temperature at evaporator 12/7°C – water temperature at condenser 15 - 30°C
 Sound power measured according to standards ISO 3741 - ISO 3744 and EN 29614-1

RATED TECHNICAL DATA of MCW H heat pumps								
MCW - HS / HL		005 M	005	007 M	007	010 M	010	012
Cooling capacity	kW	5,30	5,30	6,80	6,80	9,60	9,60	11,80
Rated input power in cooling mode	kW	1,32	1,30	1,74	1,70	2,34	2,30	2,75
Rated current absorption in cooling mode	A	6,26	2,62	8,27	3,47	11,21	4,71	5,63
Evaporator water flow rate	l/h	911	911	1.170	1.169	1.651	1.651	2.029
Pressure drops, evaporator side	kPa	25	25	29	29	25	25	29
Condenser water flow rate	l/h	376	375	485	482	678	675	826
Pressure drops – condenser side	kPa	4	4	6	6	4	4	6
Heating capacity	kW	6,02	5,9	7,75	7,6	10,8	10,6	13,1
Rated input power in heating mode	kW	1,67	1,64	2,19	2,14	2,96	2,9	3,47
Rated current absorption in heating mode	A	8,51	3,28	11,51	4,44	15,63	5,99	7,05
Condenser water flow rate	l/h	1.035	1.015	1.334	1.307	1.858	1.823	2.254
Pressure drops – condenser side	kPa	30	29	45	43	32	31	47
Power supply	V-ph-Hz	230-1-50	400-3-50 + N	230-1-50	400-3-50 + N	230-1-50	400-3-50 + N	400-3-50 + N
Maximum absorbed current	A	12	4,2	15	5,1	23,1	7	10
Inrush current	A	47	24	61	32	100	46	50
Scroll compressors / cooling circuits	No.	1	1	1	1	1	1	1
Water content in user section	dm ³	2,1	2,1	2,1	2,1	2,6	2,6	2,6
Pump available head (option)	kPa	91	92	84	85	78	79	148
Pump electrical output (option)	kW	0,25	0,25	0,25	0,25	0,25	0,25	0,33
Buffer tank (option)	dm ³	47	47	47	47	47	47	92
GAS water connections		1"	1"	1"	1"	1"	1"	1" 1/2
Height	mm	830	830	830	830	830	830	1.270
Length	mm	705	705	705	705	705	705	812
Depth	mm	453	453	453	453	453	453	508
Standard unit weight	kg	106	106	109	109	112	112	123
MCW-HS: Sound power level	dB(A)	55	55	55	55	59	59	61
MCW-HL: Sound power level	dB(A)	53	53	53	53	57	57	59
RATED TECHNICAL DATA of MCW H heat pumps								
MCW - HS / HL		015	018	020	022	027	031	039
Cooling capacity	kW	14,50	17,30	20,10	21,20	26,10	30,30	37,50
Rated input power in cooling mode	kW	3,40	3,89	4,40	4,90	6,30	7,20	8,90
Rated current absorption in cooling mode	A	7,43	7,37	9,37	10,20	13,15	15,23	17,38
Evaporator water flow rate	l/h	2.494	2.976	3.458	3.647	4.489	5.212	6.450
Pressure drops, evaporator side	kPa	26	28	26	27	24	27	26
Condenser water flow rate	l/h	1.016	1.204	1.392	1.483	1.840	2.130	2.635
Pressure drops – condenser side	kPa	4	6	5	6	5	7	7
Heating capacity	kW	16	19,2	21,6	23,59	29	33,6	41,7
Rated input power in heating mode	kW	4,28	4,91	5,5	6,2	7,9	9,1	11,2
Rated current absorption in heating mode	A	8,95	9,88	11,89	12,63	16,34	19,04	22,34
Condenser water flow rate	l/h	2.751	3.303	3.715	4.058	4.989	5.779	5.343
Pressure drops – condenser side	kPa	13	46	37	46	38	50	18
Power supply	V/Ph/Hz	400-3-50 + N						
Maximum absorbed current	A	66	14	16	17	20	29	32
Inrush current	A	31	74	101	98	130	130	135
Scroll compressors / cooling circuits	No.	1	1	1	1	1	1	1
Plate evaporator	No.	1	1	1	1	1	1	1
Plate condenser	No.	1	1	1	1	1	1	1
Water content in user section	dm ³	3,1	3,1	3,6	3,6	3,9	4,3	4,6
Pump available head (option)	kPa	148	140	122	158	151	139	149
Pump electrical output (option)	kW	0,33	0,33	0,45	0,45	0,45	0,45	0,75
Buffer tank (option)	dm ³	92	92	92	92	92	92	92
Water connections GAS type		1" 1/2	1" 1/2	1" 1/2	1" 1/2	1" 1/2	1" 1/2	1" 1/2
Height	mm	1.270	1.270	1.270	1.270	1.270	1.270	1.270
Length	mm	812	812	812	812	812	812	812
Depth	mm	508	508	508	508	508	508	508
Standard unit weight	kg	125	132	175	209	221	236	247
MCW-HS: Sound power level	dB(A)	55	55	55	55	59	59	61
MCW-HL: Sound power level	dB(A)	53	53	53	53	57	57	59

Cooling capacity refers to the following conditions: water temperature at evaporator 12/7°C – water temperature at condenser 15 - 30°C

Heating capacity: water temperature at evaporator 15°C, water temperature at condenser 40 - 45°C.

Sound power measured according to standards ISO 3741 - ISO 3744 and EN 29614-1

MCR CONDENSERLESS WATER CHILLERS IN STANDARD AND LOW NOISE VERSIONS

MCR condenserless water chillers derived from the MCW range of water-condensed chillers and are offered in standard and low-noise versions for cooling only.

The numerous optional features available to complete the units include remote condensers with vertical or horizontal flow axial fans in standard and low-noise versions and a heat recovery system (with desuperheater).

The mechanical Y filter is COMPULSORY on all models to protect the heat exchangers (user side).



RATED TECHNICAL DATA OF MCR C MOTOR DRIVEN EVAPORATING UNITS								
MCR - CS / CL		005 M	005	007 M	007	010 M	010	012
Cooling capacity	kW	4,8	4,8	6,2	6,2	8,6	8,6	10,76
Rated input power	kW	1,63	1,6	2,16	2,1	2,96	2,9	3,5
Rated current absorption	A	7,63	2,96	9,99	3,77	13,84	5,36	6,3
Power supply	V-ph-Hz	230-1-50	400-3-50 + N	230-1-50	400-3-50 + N	230-1-50	400-3-50 + N	400-3-50 + N
Maximum absorbed current	A	12	4,2	15	5,1	23,1	7	10
Inrush current	A	47	24	61	32	100	46	50
Evaporator water flow rate	l/h	825	825	1.066	1.067	1.478	1.480	1.851
Pressure drops, evaporator side	kPa	26	26	30	30	26	26	30
Scroll compressors / cooling circuits	No.	1 / 1	1 / 1	1 / 1	1 / 1	1 / 1	1 / 1	1 / 1
Plate evaporator	No.	1	1	1	1	1	1	1
Water content in user section	dm ³	2,1	2,1	2,1	2,1	2,6	2,6	2,6
Pump available head (option)	kPa	81	81	72	72	67	67	133
Pump electrical output (option)	kW	0,25	0,25	0,25	0,25	0,25	0,25	0,33
Buffer tank (option)	dm ³	47	47	47	47	47	47	92
Height	mm	830	830	830	830	830	830	1.270
Length	mm	705	705	705	705	705	705	812
Depth	mm	453	453	453	453	453	453	508
MCR-CS: Sound power level	dB(A)	55	55	55	55	59	59	61
MCR-CL: Sound power level	dB(A)	53	53	53	53	57	57	59

RATED TECHNICAL DATA OF MCR C MOTOR DRIVEN EVAPORATING UNITS								
MCR - CS / CL		015	018	020	022	027	031	039
Cooling capacity	kW	13	15,6	17,6	19,2	23,5	27,3	33,9
Rated input power	kW	4,3	5	5,6	6,2	8	9,1	11,2
Rated current absorption	A	8,39	8,85	10,76	11,52	15,04	16,96	19,97
Power supply	V-ph-Hz	400-3-50 + N						
Maximum absorbed current	A	13	14	16	17	20	29	32
Inrush current	A	66	74	101	98	130	130	135
Evaporator water flow rate	l/h	2.236	2.683	3.028	3.302	4.042	4.695	5.831
Pressure drops, evaporator side	kPa	26	29	26	29	26	29	28
Scroll compressors / cooling circuits	No.	1 / 1	1 / 1	1 / 1	1 / 1	1 / 1	1 / 1	1 / 1
Plate evaporator	No.	1	1	1	1	1	1	1
Water content in user section	dm ³	3,1	3,1	3,6	3,6	3,9	4,3	4,6
Pump available head (option)	kPa	125	107	145	136	122	101	136
Pump electrical output (option)	kW	0,33	0,33	0,45	0,45	0,45	0,45	0,75
Buffer tank (option)	dm ³	92	92	92	92	92	92	92
Height	mm	1.270	1.270	1.270	1.270	1.270	1.270	1.270
Length	mm	812	812	812	812	812	812	812
Depth	mm	508	508	508	508	508	508	508
MCR-CS: Sound power level	dB(A)	61	61	61	62	62	62	65
MCR-CL: Sound power level	dB(A)	59	59	59	60	60	60	63

Cooling capacity refers to the following conditions: water temperature at evaporator 12/7°C – air temperature at condenser 35°C
 Sound power measured according to standards ISO 3741 - ISO 3744 and EN 29614-1

COMPACT REVERSIBLE AIR/WATER HEAT PUMPS

REFRIGERANT: R410A

EXTREMELY LOW NOISE LEVELS

LOW DIMENSIONS

- 1190 x 340 x 735 mm
- 1190 x 340 x 1235 mm

TOP QUALITY COMPONENTS

INTEGRATED HYDRONIC MODULE:

- 3 speed circulation pump
- Expansion tank
- Safety valve
- Air vent valves
- Pressure gauges
- Hydraulic filter

FUNCTIONS OF THE CONTROL SYSTEM

- Reduction in minimum volume of water in the system
- Condensation pressure regulation
- Automatic control of the circulation pump (antifreeze function, anti-seizure function)
- Defrost regulation according to the outdoor temperature
- Management of alarms with recording of events
- External communication via a serial interface (Modbus protocol)

OTHER ADVANTAGES

- Easy access to components
- Keypad/display on front panel
- Partition between the fan and technical compartment
- Removable control panel to permit a larger opening
- Rigorous control of production: tightness test of the cooling circuit, electric, dielectric test, water circuit test, etc.

STANDARD EQUIPMENT:

- Single-phase start-up kit (MSHRT 7/9/12 single-phase)
- Water flow control
- Proportional "four-season" adjustment
- Low pressure switch
- High pressure switch
- Water filter (to be connected)
- Integrated hydronic module



HEATING AND COOLING

Rated water temperature in heating mode	40/45°C
Rated water temperature in cooling mode	7/12°C

OPERATING LIMITS

Outdoor air temperature:	-16°C in heating mode, +43°C in cooling mode
Maximum water outlet temperature:	+55°C in heating mode

TECHNICAL DATA of MSHRT heat pumps

MODEL		MSHRT 075	MSHRT 095	MSHRT 125	MSHRT 127	
Power supply		230/1/50	230/1/50	230/1/50	400/3/50	
HEATING	Conditions: inlet/outlet water temperature 40/45° C, inlet air temperature 7/6° C (D.B./W.B.); net values; EN 14511-2					
	Rated heating capacity	kW	7,2	9,17	10,5	12,4
	Rated input power	kW	2,65	3,19	3,62	4,06
	C.O.P	kW/kW	2,72	2,87	2,9	3,05
	Nominal water flow rate	m³/h	1,19	1,58	1,87	2,16
	Pump available head	kPa	57	47	66	53
	Conditions: inlet/outlet water temperature */45° C, inlet air temperature -7/-8° C (D.B./W.B.); net values; EN 14511-2					
	Rated heating capacity	kW	4,6	5	5,88	6,8
	Rated input power	kW	2,87	3,23	3,77	4,25
	C.O.P	kW/kW	1,6	1,55	1,56	1,6
	Conditions: inlet/outlet water temperature */55° C, inlet air temperature 7/6° C (D.B./W.B.); net values; EN 14511-2					
	Rated heating capacity	kW	6	8,25	9,38	11,7
	Rated input power	kW	3,04	3,75	4,04	4,73
	C.O.P	kW/kW	1,97	2,17	2,32	2,47
Conditions: inlet/outlet water temperature 40/45° C, inlet air temperature 7/6° C (D.B./W.B.); gross values; Eurovent						
Rated heating capacity	kW	7,25	9,24	10,65	12,5	
Rated input power	kW	2,56	3,12	3,48	4,1	
C.O.P	kW/kW	2,83	2,96	3,06	3,05	
Conditions: inlet/outlet water temperature 30/35° C, inlet air temperature 7/6° C (D.B./W.B.); net values; Ref.						
C.O.P	kW/kW	3,42	3,41	3,66	3,84	
COOLING	Conditions: inlet/outlet water temperature 12/7° C, inlet air temperature 35° C (D.B.); gross values; Eurovent					
	Rated cooling capacity	kW	5,90	7,10	8,56	9,00
	Rated input power	kW	2,55	3,14	3,33	3,73
	E.E.R.	kW/kW	2,31	2,26	2,57	2,41
	Water flow rate	m³/h	1,01	1,22	1,48	1,51
	Pump available head	kPa	64	59	82	80
Type of refrigerant		R410A	R410A	R410A	R410A	
Number of cooling circuits	no.	1	1	1	1	
Nbr of compressors	no.	1	1	1	1	
Starting current	A	40	33	34	56	
Expansion tank	l	2	2	2	2	
Diameter of male water connection		3/4"	3/4"	1"	1"	
Sound power level	dBA	65	65	67	67	
Min/max water content of system	l	30/60	40/90	50/90	50/90	
Net dimensions (H/L/D)	mm	735x1190x340	735x1190x340	1235x1190x340	1235x1190x340	
Net weight	kg	98	98	128	128	

CLEARANCE REQUIREMENTS

A 150 mm for models 075 and 095
250 mm for models 125 and 127

This dimension does not take into account configurations including the installation of a hydraulic filter with two isolation valves positioned straight behind the unit: allow for 0.30 metres.

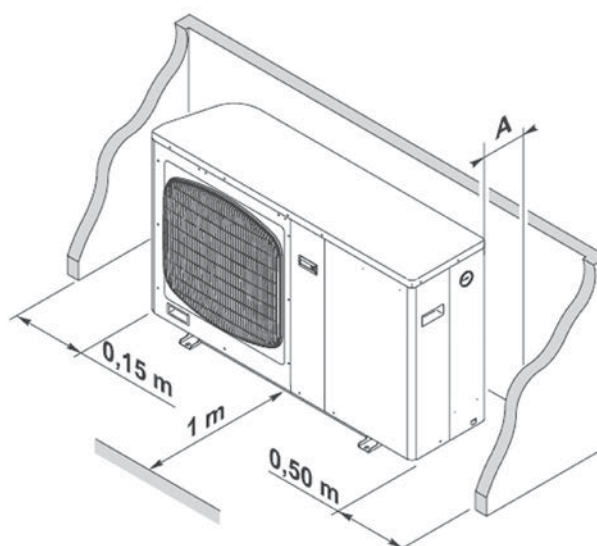

AIR-COOLED CONDENSING UNITS

To be used in systems in two sections, MTE units can be combined with DX exchanger coils of air handling units.

MTE outdoor condensing units were developed on the basis of the MPE and LCE series and offer a high level of efficiency combined with extremely low noise levels.

They are supplied complete with:

- > Shut-off valves on the liquid and gas line
- > Heating element on the compressor crankcase to prevent oil from being diluted during off cycles
- > Nitrogen precharge under pressure
- > Schrader valves for pressure-controlled charging operations
- > Humidity and liquid flow indicator mounted so as to be visible from the outside with no need to remove the panels
- > Electrical control panel with microprocessor controller accessible from the outside and low-voltage output for dry-contact thermostatic control of the unit, external disconnect switch, phase sequence control, compressor protection, compressor start-up time delay device.



Technical data of MTE condensing units																
MTE-C		005 M	007 M	009 M	009	010 M	010	012	013	015	018	021	024	029	033	038
Power supply	V-ph-Hz	230-1-50	230-1-50	230-1-50	400-3N-50	230-1-50	400-3N-50	400-3N-50	400-3N-50	400-3N-50	400-3N-50	400-3N-50	400-3N-50	400-3N-50	400-3N-50	400-3N-50
Cooling capacity	kW	5,40	7,11	9,12	9,15	9,60	9,58	12,15	13,43	15,26	18,42	20,79	24,41	29,26	32,95	37,70
Total power input	kW	1,72	2,30	3,34	3,15	3,36	3,36	4,42	4,43	5,48	6,65	7,50	8,42	9,88	11,45	12,27
EER		3,15	3,10	2,73	2,91	2,86	2,85	2,75	3,03	2,78	2,77	2,77	2,90	2,96	2,88	3,07
Maximum power input	kW	2,4	3,1	4,1	4,1	4,5	4,6	5,9	5,9	6,9	8,6	9,3	10,7	14,0	15,9	17,4
Maximum current absorbed	A	12,2	15,7	20	7,4	22,8	8,6	10,8	10,9	12,5	16,9	18	20,4	28,18	31,44	34,01
Starting ampere	A	63	63	63	45	97	48	63	63	66	73	102	102	130	163	158
n° of scroll compressors / circuits		1/1	1/1	1/1	1/1	1/1	1/1	1/1	1/1	1/1	1/1	1/1	1/1	1/1	1/1	1/1
Rated amount of refrigerant requested	kg	1,5	2	2	2	2,3	2,3	2,3	3	3	3,8	3,8	4,1	3,6	4,0	5,5
High/low pressure switch	bar	2/42	2/42	2/42	2/42	2/42	2/42	2/42	2/42	2/42	2/42	2/42	2/42	2/42	2/42	2/42
n° of axial fans		1	1	1	1	2	2	2	2	2	2	2	2	4	4	4
Air flow	m³/h	3.635	3.406	3.406	3.406	6.686	6.686	6.686	5.986	5.986	11.940	11.940	11.460	21.500	21.500	19.700
Gas line connection	mm	16	16	16	16	22	22	22	22	22	28	28	28	32	32	32
Liquid line connection	mm	10	10	10	10	12	12	12	12	12	16	16	16	16	16	16
Height	mm	758	758	758	758	1.225	1.225	1.225	1.225	1.225	1.225	1.225	1.225	1.275	1.275	1.275
Length	mm	960	960	960	960	1.220	1.220	1.220	1.220	1.220	1.220	1.220	1.220	1.565	1.565	1.565
Width	mm	450	450	450	450	550	550	550	550	550	550	550	550	601	601	601
Sound Power level	dB(A)	67	67	67	67	69	69	69	70	70	77	77	77	80	80	80
Sound pressure level	dB(A)	39	39	39	39	41	41	41	42	42	49	49	49	52	52	52
Liquid Receiver (option)	dm³	1,3	1,3	1,3	1,3	4,2	4,2	4,2	4,2	4,2	4,2	4,2	4,2	7,8	7,8	7,8
Weights	kg	72	85	94	94	165	165	168	170	170	175	190	204	230	239	259
MTE-C		042	053	059	066	074	082	096	108	129	142	163	169	193	214	
Power supply	V-ph-Hz	400-3N-50	400-3N-50	400-3N-50	400-3N-50	400-3N-50	400-3N-50	400-3N-50	400-3N-50	400-3N-50	400-3N-50	400-3N-50	400-3N-50	400-3N-50	400-3N-50	
Cooling capacity	kW	42,29	52,95	58,5	66	73,74	82,05	96,21	107,72	128,74	141,95	163,41	169,06	192,59	213,66	
Total power input	kW	13,45	16,21	18,22	21,27	23,64	27,77	32,93	38,42	40,95	45,95	57,86	55,88	66,2	78,47	
EER		3,14	3,27	3,21	3,1	3,12	2,95	2,92	2,8	3,14	3,09	2,82	3,03	2,91	2,72	
Maximum power input	kW	19,2	24,4	26,3	30,1	33,2	37,9	43,4	49,8	54,9	60,1	74,5	75,6	85,4	100,6	
Maximum current absorbed	A	35,8	45,8	49,2	55,7	60,8	68,8	80,8	90,5	103,3	112,5	136,5	137,1	155,0	174,3	
Starting ampere	A	160	167	170	180	195	214	238	276	303	311	382	251	305	322	
n° of scroll compressors / circuits		1/1	2/1	2/1	2/1	2/1	2/1	2/1	2/1	2/1	2/1	2/1	4/2	4/2	4/2	
Rated amount of refrigerant requested	kg	7,0	10	10	12	10,3	13,8	13,8	18	20	22,8	29,5	32	30	32	
High/low pressure switch	bar	2/42	2/42	2/42	2/42	2/42	2/42	2/42	2/42	2/42	2/42	2/42	2/42	2/42	2/42	
n° of axial fans		2	4	4	4	4	4	6	6	8	8	8	6	6	6	
Air flow	m³/h	21.230	24.930	24.930	24.930	24.354	24.354	36.180	36.180	46.839	46.839	46.839	65.223	65.223	65.223	
Gas line connection	mm	35	35	35	35	35	35	42	42	42	42	42	54	54	54	
Liquid line connection	mm	16	22	22	22	22	22	28	28	28	28	28	28	28	28	
Height	mm	1.485	1.720	1.720	1.720	1.720	1.720	1.720	1.720	1.720	1.720	1.720	1.830	1.830	1.830	
Length	mm	1.990	2.010	2.010	2.010	2.010	2.010	2.360	2.360	3.190	3.190	3.190	3.540	3.540	3.540	
Width	mm	950	1.185	1.185	1.185	1.185	1.185	1.185	1.185	1.185	1.185	1.185	1.654	1.654	1.654	
Sound Power level	dB(A)	82	76	76	76	77	80	82	82	82	82	83	83	84	84	
Sound pressure level	dB(A)	54	48	48	48	49	52	54	54	54	55	55	55	56	56	
Liquid Receiver (option)	dm³	10	10	10	10	10	10	8	8	12	12	12	12	12	12	
Weights	kg	360	525	530	540	570	650	730	730	1010	1055	1085	1330	1460	1470	

- Cooling capacity: outdoor air temperature 35°C, evaporation temperature 5°C

- Sound pressure measured at a distance of 10 m and a height of 1.5 m above the ground in a clear field (fan side).

dedicated
heat pumps
solutions

HIWARM
MCP
DHW TANKS
LCP
MSHTJ
EMC

HIGH EFFICIENCY TOTAL HEAT RECOVERY MULTI-PURPOSE MODULATING SYSTEM

- > SPLIT VERSION
- > HEATING
- > COOLING
- > DEHUMIDIFICATION
- > DOMESTIC HOT WATER
- > USING RENEWABLE HEATING SOURCES
- > MAXIMUM ENERGY EFFICIENCY
- > TOTAL HEAT RECOVERY
- > INTEGRATED HYDRONIC SYSTEM
- > TOTAL SAFETY

HiWarm is a multi-purpose total condensation heat recovery split heat pump.

Exchanging heat with external air enables the room to be conditioned and to produce hot water for sanitary purposes without the use of electric elements. During summer time the cooling system is capable of producing hot water and chilled water simultaneously.

There are 3 sizes available, classified on the basis of cooling capacity to be delivered at the maximum power frequency of the compressor.

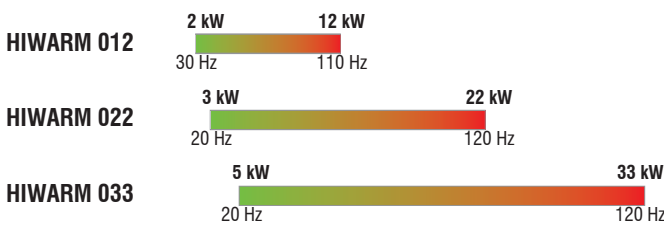

The characteristics shared by all 3 sizes of HiWarm units can be summed up as follows:

- Indoor unit where the compressor is housed so as both to reduce outdoor noise emissions and allow the construction of a lightweight outdoor unit that can be positioned above the ground with simple brackets.
- Remote dissipator where the coil and the fans are housed. It is available in a version for outdoor installation and in a duct version for indoor installation.

Main constructive features of HiWarm units:

- Double water circuit.
- Air conditioning circuit with reversible system on cooling circuit side and water side and min/max variable set-point through a voltage-free contact or from min/max through a 0-10V or 4-20mA signal.
- ACS circuit with total recovery (in the event of simultaneous cooling) or in any case with recovery as a priority. This circuit is separate and unlike in other similar products on the market it does not require long heating/cooling phases for inertial storage which impair energy efficiency, above all in summertime.
- Scroll or twin-rotary compressors - BLDC brushless technology.
- Exchangers with high efficiency braze-welded AISI 316 plates.
- Highly efficiency fans.
- Throttle valve: EEV (electronically controlled electric thermal expansion valve) to take advantage from the possibility of generating thermodynamic cycles under reduced pressure let-downs, resulting in clear benefits in terms of COP.
- Integrated control of pumps on the system side and the DHW side: Both pumps are modulating pumps with permanent magnets electric synchronous motor.
- Advanced electronic control allowing to meet the load control step requirements.

These critical components guarantee an optimal performance under part load conditions, which are increasingly taken into consideration and are a discriminating factor in the choice of thermal engineers.

WINTER

Heating + domestic hot water



IN THE WINTER SEASON HIWARM CAN PRODUCE HOT WATER FOR THE HEATING SYSTEM AS WELL AS DOMESTIC HOT WATER, WITH OUTDOOR TEMPERATURES AS LOW AS -15°C AND WATER TEMPERATURES OF UP TO 60°C.

MILD CLIMATES

domestic hot water only

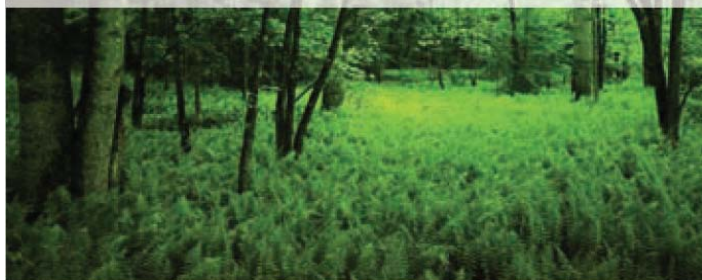

DURING IN-BETWEEN SEASONS HIWARM CAN PRODUCE ONLY DOMESTIC HOT WATER, WHEREAS THE AIR CONDITIONING SYSTEM - SUMMER AND WINTER MODES - REMAINS OFF

SUMMER

Domestic hot water + cooling



IN THE SUMMERTIME OPERATING MODE, DOMESTIC HOT WATER AND CHILLED WATER ARE PRODUCED AT "ZERO COST" SIMULTANEOUSLY AND USED FOR ROOM AIR COOLING AND/OR DEHUMIDIFICATION REQUIREMENTS

SUMMER

Domestic hot water + cooling and dehumidification

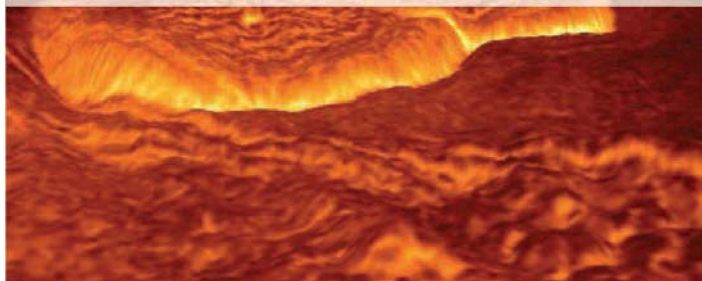

STRUCTURAL COMPONENTS

INDOOR UNIT

Galvanised steel perimeter enclosure panels with an epoxy polyester powder coating, oven cured at 180°C, and front plexiglass cover which also incorporates the display (LCD).

All components of the unit are accessible from the front of the unit, by simply removing the front panel.

The BLDC compressor, the high efficiency modulating pumps, the two braze-welded plate exchangers, the electronic expansion valve, the onboard controller, the cycle reversing valve on the water side and the solenoid valves are housed in the indoor unit.

REMOTE UNIT FOR OUTDOOR INSTALLATION

Panels coated with epoxy polyester powder paint oven cured at 180°C.

The unit is completely enclosed with panels and available in RAL9002 (Grey White). The fans and the finned coil are housed in the outdoor unit. 6 pole axial fans with blades ensuring broad coverage, associated with external rotor asynchronous motors (or synchronous permanent magnets) and fan continuous speed modulation.

EC fans equipped with permanent magnets synchronous motors are available as option.

REMOTE UNIT FOR INDOOR INSTALLATION (ATTIC)

Galvanised sheet steel panelling, coated with epoxy polyester powder paint oven cured at 180°C.

The unit is completely enclosed with panels and available in RAL9002 (Grey White).

Centrifugal fans with reaction impellers and backward curved blades combined with brushless BLDC motors to ensure continuous efficient modulation.

Maximum head available at 200 Pa.

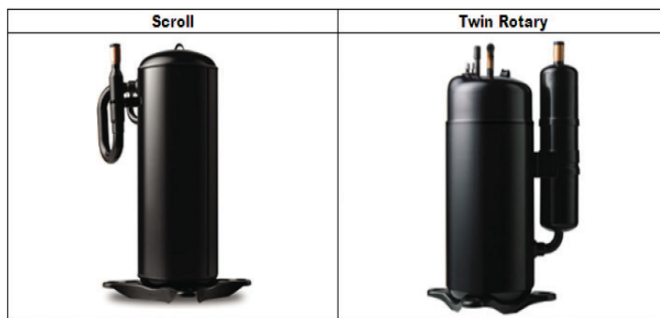

COMPRESSORS

Hermetic scroll compressors (respectively for the 22 DC and 33 DC) or twin rotary compressors (for the 12 DC), complete with motor protection against temperature and current overloads and excessive temperatures of the outgoing gas.

Mounted on rubber vibration dampers, complete with oil charge and housed in a compartment that is soundproofed with sound absorbing material. They are also equipped with an automatic oil heater to prevent the oil from being diluted by the refrigerant when the compressor stops.

Brushless permanent magnet AC compressor motor controlled by a trapezoidal wave driver within a speed range between 30 (20) and 120 Hz (BLDC "Brushless Direct Current" technology).

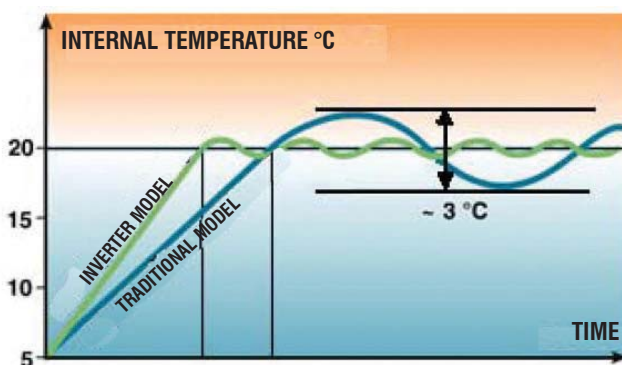

INTERNAL EXCHANGERS

All units have heat exchangers with braze-welded AISI 316 austenitic stainless steel plates and connections made of AISI 304 L, characterised by a reduced carbon content to facilitate brazing.

Braze-welded plate exchangers represent the state of the art in terms of heat exchange efficiency and make it possible to significantly reduce the refrigerant charge compared to traditional solutions.

The high turbulence induced by the internal corrugation of the plates and the perfectly smooth surface of the plates themselves also hinders the build-up of dirt. The high thermal exchange coefficient on the refrigerant side, in combination with the new plate geometry, enables a much shorter approach to the T set-points, with clear benefits in terms of energy.

PUMPS

Use wet-rotor circulation pumps with EC motors, maintenance free, high efficiency (class A) and electronically controlled.

The pump casing is made of grey cast iron with a cataphoretic KTL coating, which provides optimal protection against corrosion. The thermal insulation is polypropylene, the shaft is stainless steel, the bearings are made of metal-impregnated carbon and the rotor, with a three-dimensional spiral is made of a synthetic material with a hermetic insulating coating of composite carbon fibre material.

They are supplied with a heat-insulating shell for heating applications and insulating preformed shells for cooling.



ELECTRONICALLY CONTROLLED ELECTRIC THROTTLE VALVE

An electronically controlled electronic valve is used instead of a classic mechanical thermostatic valve, because it is able to handle transients in a shorter time and to operate with very small ΔP .

The shutter in the central part of the valve can always slide vertically with a wide range of movement to allow the orifice through which the fluid passes to be opened by varying degrees.

Using this valve makes it possible to reduce the amount of energy consumed by the compressor when the surrounding conditions allow the difference between the condensation and evaporation pressures to be reduced to values below 5 bar.



CYCLE REVERSING VALVE ON WATER SIDE

HiWarm units are reversible: when switched from the cooling to heat pump mode and vice versa, they carry out two cycle reversals. One on the refrigerant side and one on the water side.

The cycle reversing valve on the water side is switched from position A to position B (in less than 20 seconds) and vice versa by means of an electric driver, without changing the direction of flow for users; this allows the direction of flow to be reversed in the exchangers, so that it is always opposite the direction of flow of the refrigerant fluid.



The WEB circuit card allows a connection to be made between the onboard controller of the unit and the 10 Mbps Ethernet RJ45 network. The operating system used is Linux 2.4.21 . Installation takes place directly on the serial port of the advanced controller and a static or dynamic IP address with DHCP function is used.

The supervision software permits the following:

- Display of unit status
- Display of current alarms and alarm history
- Recording of data with 10 settable variables
- Downloading of all data records via a web browser or FTP
- Possibility of editing the main parameters
- Sending of e-mails to 5 different recipients in case of alarm

With supervision software it is also possible to perform supervisory monitoring using the following protocols:

- SNMP v1 & v2c
- BACnet Ethernet or BACnet/IP

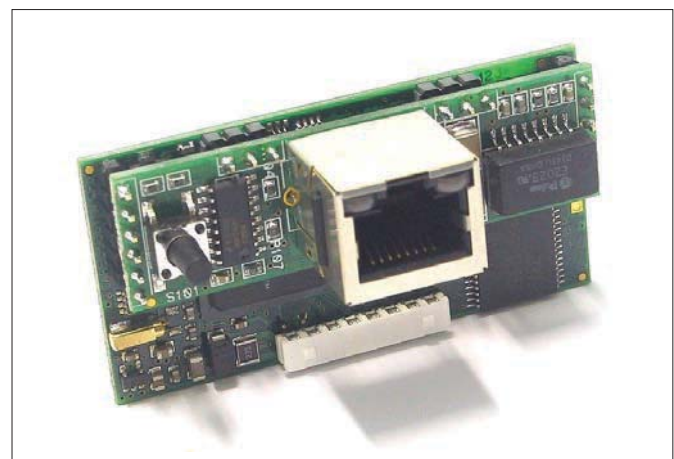
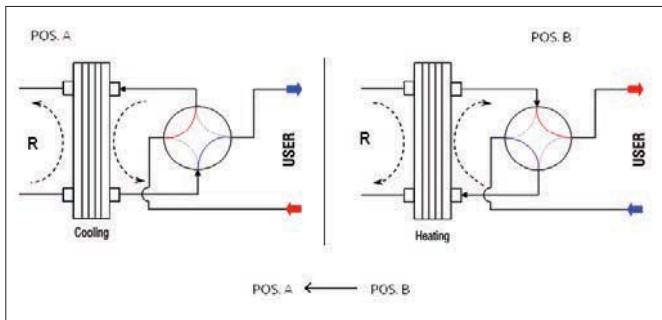

Functions of on-board control system:

- Control of the different operating parameters
- Modulation of the compressor to maintain the outlet temperature set point of heat pump
- Management of alarms (high/low pressure, antifreeze, flow switch, pump alarm)
- Management of pumps
- Display of operating parameters
- Antifreeze protection of heat exchangers
- Management of the maximum number of compressor start-ups
- Serial output management (optional)
- Interfaceability via WEB with the Webgate option; all it takes is a simple connection and any Internet browser can be used
- Summer/winter and on/off switching through clean contact or on-board control

THE SUPERVISION SOFTWARE integrated into the unit is available.

TECHNICAL DATA

Thermodynamic performances of HiWarm units equipped with electronic pumps (standard) and electronic control fans (optional) have been reported in accordance with standard EN14511-2400. ESEER values have been calculated in accordance with Eurovent standards. Performances have been calculated for a maximum length of 10 m for the gas lines connecting the internal unit to the remote one (internal or external).

		Hi Warm012		Hi Warm022		Hi Warm033		
Compressor speed		[Hz]	30	110	30	120	30	120
ESEER radiant panels (user @ 23-18°C) *			8.61		6.69		6.52	
ESEER Eurovent fan-coils (user @ 12-7°C)			5.65		5.30		5.24	
Cooling @ 35°C air 12/7°C water	Cooling capacity	[kW]	3.0	11.2	6.0	20.4	9.6	31.9
	Compressor input power	[kW]	0.6	3.1	1.3	7.0	2.1	11.0
	Compressor input current	[A]	7.4	8.3	11.1	12.6	16.6	19.8
	Fan input power	[kW]	0.08	0.30	0.07	0.45	0.06	0.60
	Fan input current	[A]	0.40	1.40	0.10	0.80	0.10	1.10
	EER	[-]	4.41	3.26	4.38	2.71	4.50	2.72
	USER water flow rate	[kg/h]	519	1921	1026	3517	1646	5480
	USER water pressure drops	[kPa]	2.0	19.0	3.0	26.0	3.0	23.0
	DISSIPATION air flow rate	[m³/h]	3500	7000	5250	10500	7000	14000
Cooling @ 35°C air 23/18°C water	Cooling capacity	[kW]	4.2	15.7	8.5	28.1	8.6	44.0
	Compressor input power	[kW]	0.6	3.2	1.3	7.5	1.2	11.8
	Compressor input current	[A]	6.9	8.6	10.9	13.2	3.2	20.4
	Fan input power	[kW]	0.08	0.30	0.06	0.45	0.05	0.60
	Fan input current	[A]	0.40	1.40	0.10	0.80	0.10	1.10
	EER	[-]	6.27	4.41	6.34	3.46	6.80	3.47
	USER water flow rate	[kg/h]	714	2696	1458	4834	1472	7565
	USER water pressure drops	[kPa]	3.0	37.0	4.0	49.0	11.1	44.0
	DISSIPATION air flow rate	[m³/h]	3500	7000	5250	10500	7000	14000
DHW @ 50/55°C and 30°C outdoor air	Heating capacity	[kW]	3.3	16.6	7.6	32.3	11.8	51.7
	Compressor input power	[kW]	0.9	4.3	2.1	9.5	3.2	14.2
	Compressor input current	[A]	12.8	18.4	15.2	23.7	20.2	25.9
	Fan input power	[kW]	0.08	0.30	0.06	0.45	0.05	0.60
	Fan input current	[A]	0.40	1.40	0.10	0.80	0.10	1.10
	COP	[-]	3.46	3.54	3.58	3.14	3.63	3.37
	DHW water flow	[kg/h]	714	2860	1307	5563	2169	8885
	DHW pressure drops	[kPa]	3.0	41.0	4.0	64.0	4.0	61.0
	DISSIPATION air flow rate	[m³/h]	3500	7000	5250	10500	7000	14000
Cooling + DHW @ 50/55°C and 12/7°C	Cooling capacity	[kW]	2.4	9.2	4.7	17.1	7.9	28.1
	Heating capacity	[kW]	3.2	13.1	6.4	25.5	10.6	40.9
	Compressor input power	[kW]	0.9	4.1	1.8	8.9	2.9	13.4
	Compressor input current	[A]	10.6	11.0	14.8	15.3	22.7	23.7
	Fan input power	[kW]	0.0	0.0	0.0	0.0	0.0	0.0
	Fan input current	[A]	0.0	0.0	0.0	0.0	0.0	0.0
	COP	[-]	3.55	3.16	3.49	2.86	3.68	3.03
	USER water flow rate	[kg/h]	407	1580	806	2944	1357	4839
	USER water pressure drops	[kPa]	1.0	13.0	3.0	18.0	3.0	18.0
	DHW water flow	[kg/h]	556	2252	1107	4393	1829	7026
DHW pressure drops	[kPa]	2.0	26.0	4.0	40.0	4.0	38.0	

* Value calculated according to the same procedure as ESEER Eurovent Fan-coils (user @ 12-7°C).

TECHNICAL DATA

		Hi Warm012		Hi Warm022		Hi Warm033		
Compressor speed		[Hz]	30	110	30	120	30	120
ESEER radiant panels (user @ 23-18°C) *			8.61		6.69		6.52	
ESEER Eurovent fan-coils (user @ 12-7°C)			5.65		5.30		5.24	
BT Heating @ 30-35°C and 7°C outdoor air	Heating capacity	[kW]	2.9	11.7	5.8	22.7	9.4	34.9
	Compressor input power	[kW]	0.7	3.3	1.5	7.1	2.3	10.8
	Compressor input current	[A]	8.6	8.9	12.3	12.7	18.9	19.6
	Fan input power	[kW]	0.30	0.30	0.45	0.45	0.60	0.60
	Fan input current	[A]	1.40	1.40	0.80	0.80	1.10	1.10
	COP	[-]	2.84	3.23	3.00	2.95	3.21	3.02
	USER water flow rate	[kg/h]	499	2014	1000	3903	1618	5998
	USER water pressure drops	[kPa]	2.0	21.0	4.0	32.0	4.0	28.0
	DISSIPATION air flow rate	[m³/h]	7000	7000	10500	10500	14000	14000
BT Heating @ 30-35°C and 7°C outdoor air	Heating capacity	[kW]	3.1	12.2	6.1	23.5	9.8	35.7
	Compressor input power	[kW]	0.6	2.7	1.2	5.8	1.9	8.9
	Compressor input current	[A]	7.2	7.5	10.6	11.0	15.8	16.5
	Fan input power	[kW]	0.30	0.30	0.45	0.45	0.60	0.60
	Fan input current	[A]	1.40	1.40	0.80	0.80	1.10	1.10
	COP	[-]	3.48	4.03	3.69	3.65	3.91	3.71
	USER water flow rate	[kg/h]	527	2093	1050	4034	1687	6147
	USER water pressure drops	[kPa]	2.0	22.0	4.0	34.0	4.0	29.0
	DISSIPATION air flow rate	[m³/h]	7000	7000	10500	10500	14000	14000
Electrical input	Power supply		single-phase 230/1/50		three-phase 400/3/50		three-phase 400/3/50	
	FLA with fans adjusted by potentiometer	[A]	21,8		23,0		33,2	
	FLA with EC electronic fans	[A]	21,2		22,0		31,8	
Noise emissions	Lw sound power level - internal unit	[dBA]	54		55		57	
	Lp sound pressure level (10m Q=2) internal unit	[dBA]	26		27		29	
	Lw sound power level - external unit	[dBA]	65		66		69	
	Lp sound pressure level (10m Q=2) external unit	[dBA]	37		38		41	
Compressor	Compressor type		Twin Rotary		Scroll		Scroll	
	Electric motor type		BLDC		BLDC		BLDC	
	Oil charge for compressor	[l]	1.8		1.5		1.8	
	No. of cooling circuits		1		1		1	
Dimensions, weights and connections	Internal module dimensions (LxDxH)	[mm]	803x1120x501.5		803x1247x606		803x1247x606	
	External module dimensions (LxDxH)	[mm]	1120x1230x450		1410x1280x450		2000x1512x550	
	Weight of internal module	[kg]	190		260		270	
	Weight of external module	[kg]	50		100		123	
	Dimensions of hydraulic connectors	[mm]	28		35		35	
	Cooling connections		Rotalock		Rotalock		Rotalock	

* Value calculated according to the same procedure as ESEER Eurovent Fan-coils (user @ 12-7°C).

TOTAL HEAT RECOVERY REVERSIBLE AIR/WATER HEAT PUMPS

- > HEATING
- > AIR CONDITIONING
- > COOLING
- > COOLING
- > DEHUMIDIFICATION
- > DOMESTIC HOT WATER
- > MAXIMUM ENERGY EFFICIENCY
- > TOTAL HEAT RECOVERY
- > INTEGRATED HYDRONIC SYSTEM
- > SMART DEFROST SYSTEM

MCP MULTI-PURPOSE units are designed for outdoor installation in both residential and industrial applications. The range uses R407C refrigerant, which assures high levels of performance with relatively low energy consumption and features 20 models of varying capacities indicatively from 8 to 40 kW in the cooling mode (9-47 kW in the heating mode) in nominal conditions (ref. EN14511).

The “real” multi-purpose units, with 4 water connections have been designed to cool and heat water for air conditioning and heating systems and for the production of DHW for residential or commercial use.

When reference is made to the production of domestic hot water, what is meant is the storage of thermal energy in a tank of “technical” water. Passing through a s/s coil contained inside the tank, water for domestic use is instantly heated. In this way it is possible to avoid storing domestic water and it is not necessary to provide for an anti-Legionella cycle (see recommended plumbing layouts for further details).

MCP units are NOT suitable for use as “rapid” heaters.

CONSTRUCTIVE FEATURES

Painted galvanised sheet steel structure (RAL9002) for an attractive look and effective resistance to corrosive agents.

Fastening devices are made of non-oxidizable materials, or carbon steel that has undergone surface-passivating treatments.

The compressor compartment is completely sealed and may be accessed on 3 sides thanks to easy-to-remove panels that greatly simplify maintenance and/or inspection.

Access to the compressor compartment is possible without removing the connection to the water circuit.

Sound insulation, available on request, can further reduce the noise emissions of the unit.

CUSTOMISED HYDRONIC KITS

- High head pump made entirely of stainless steel, already configured for use with mixtures of water and ethylene glycol up to 35% and provided with internal thermal protection.
It is housed in the compressor compartment and is easy to reach thanks to the removable perimeter panels.
The units can be equipped with two circulation pumps, one for the system side and one for the DHW side, and both pumps can be controlled by the onboard compressor.
- As an option it is possible to equip the unit with an inertial buffer tank, system side, that is particularly useful during a defrost cycle in particular when it is connected to low thermal inertia distribution units.
- Expansion tank
- Safety valve
- Filling cock (included)
- Automatic vent valve
- Water differential pressure switch and outlet water temperature probe with anti-freeze thermostat function
- Mechanical Y filter supplied as a standard feature on all models to protect the evaporator (included)



Electronic pumps with permanent magnets motors are available as option which are able to improve efficiency and guarantee an optimal modulation on the whole working range and the accurate control of inlet temperature

COOLING CIRCUIT

- Scroll-type compressor, optimised for heat pump applications, with R407C refrigerant, housed in a compartment that can be sound insulated
- Brazed plate heat exchanger made of stainless steel
- Finned block condenser with 9.52 mm copper piping and aluminium fins, characterised by ample heat exchange surfaces
- Dehydrating filter
- Flow indicator with humidity indicator
- Electronic thermostatic valve with advanced drivers and integrated MOP function
- Solenoid valves for managing the different operating modes of refrigerating cycles
- One-way valves
- Liquid receiver
- High and low pressure switches
- Schrader valves for checks and/or maintenance
- Refrigerant pressure gauges (optional)

FAN DRIVE ASSEMBLY

Electric fan with 6/8-pole external rotor motor directly keyed to the axial fan, with internal thermal protection on the windings, complete with safety grille and dedicated supporting structure.

The fan is housed in a special compartment having a profile designed to optimise ventilation.

The use of finned block heat exchangers of large surface reduces pressure drops on the air side, thus significantly improving the noise levels of the units.

The condensation control system continuously and automatically regulates the fan speed, further limiting the noise emissions of the unit during nighttime operation and under partial load conditions.

The pressure control is active also during DHW production as evaporation control in order to guarantee an optimal performance of the unit in all seasons.

EC electronic fans with permanent magnets motors are available as option, which are able to improve efficiency levels and guarantee an optimal modulation on the whole working range.

FINNED BLOCK HEAT EXCHANGER

Made of 9.52mm diameter copper pipes and aluminium fins, sized to guarantee maximum efficiency.

The special engineering of the heat exchangers allows defrost cycles to be carried out at maximum speed in the models with heat pump operation, which brings clear benefits in terms of the integrated efficiency of the whole cycle.

ELECTRONIC MICROPROCESSOR CONTROL

The electronic control enables the complete control of the MCP unit. It can be easily accessed through a polycarbonate flap with IP65 protection rating.

The microprocessor control is the heart of the unit and the multi-purpose system.

It is used to govern a 4 connection unit, i.e. two completely independent hydraulic circuits : on one side we have hot/chilled water production for room heating/cooling and DHW production on the other side.

Regardless of the unit configuration, the controller can govern the most suitable logic to fit the system (e.g. the circulation pumps, system side and/or DHW side can be installed inside the unit or externally, but they are always governed by the control logic through contacts present on the unit control board).

The section connected to the heating system may have an internal and/or external inertial buffer tank or not, whereas the system should always include a tank for the storage of the energy necessary for the production of DHW.

For the priority control of DHW production, the unit is equipped with a temperature sensor to be inserted in a trap of the buffer tank.

The sensor will activate the pump on the DHW side and the production of DHW once the storage temperature falls below the settable threshold value. As an alternative to a remote temperature probe, a dry contact (to be connected to the electric control board terminals) coming from an external thermostat can be used.

The self-adaptive logic theoretically enables the unit to operate even in systems where the water content is low, without the use of an inertial buffer tank.

In that case, great care should be dedicated to the evaluation of water temperatures on system side, during defrost cycles.

By reading the outdoor air temperature, it can automatically change the setpoint to adapt it to the outdoor load conditions or keep the unit running even in the harshest winter conditions.

The controller can be configured using various serial cards and enables an immediate connection to supervision networks.



Main functions:

- Control over the temperature of the heat exchanger inlet water, system side
- Control over the temperature of the heat exchanger inlet water, DHW side
- Management of DHW production, as a priority
- Management of pump operation, DHW side (if necessary according to the temperature of storage water)
- Defrosting management
- Control of fan speed
- Complete alarm management
- Dynamic control of the setpoint according to the outdoor air temperature
- Connection to an RS485 serial line for supervisory / teleassistance operation
- Option of connecting a remote terminal that duplicates the control functions

Control of the unit devices:

- Compressor
- Fans
- Solenoid valves on the refrigerating circuit
- Water circulation pump
- Antifreeze heating elements
- Alarm signalling relay

ELECTRIC CONTROL BOARD

The electric control board is constructed and wired in accordance with EEC Directive 73/23, Directive 89/336 on electromagnetic compatibility and related standards.

Made of steel sheet, it is also protected by the enclosing panels of the unit.

MCP



Multi-purpose system for condominium or industrial applications from 7 to 41 kW
Package structure with heat pump and air/refrigerant exchanger incorporated in the outdoor unit

MCP		007M	007	009M	009	010M	010	013M	013	015	018
Power supply	V-ph-Hz	230-1-50	400-3N-50	230-1-50	400-3N-50	230-1-50	400-3N-50	230-1-50	400-3N-50	400-3N-50	400-3N-50
Cooling mode											
Cooling capacity ¹	kW	7,60	7,60	9,60	9,70	11,10	11,30	13,40	13,60	15,80	19,60
Power input 1	kW	2,70	2,60	3,35	3,25	3,87	3,77	4,72	4,62	5,55	7,32
EER		3,01	3,14	3,04	3,17	3,04	3,18	3,03	3,15	3,02	2,83
Cooling mode + ACS											
Cooling capacity ¹	kW	7,20	7,30	9,00	9,10	10,60	10,80	12,80	13,00	15,40	18,40
Power input ¹	kW	2,66	2,66	3,38	3,28	3,90	3,80	4,85	4,65	5,48	7,28
Heating capacity DHW	kW	9,48	9,58	11,95	11,95	14,02	14,13	16,98	16,99	20,15	24,77
Total COP		6,18	6,26	6,14	6,35	6,27	6,51	6,07	6,37	6,41	5,88
Heating mode (system / DHW)											
Heating capacity ²	kW	8,9	8,8	11,1	11,2	12,6	12,7	15,6	15,7	18,1	23,3
Power input ²	kW	2,90	2,80	3,75	3,55	4,17	4,07	5,12	5,02	5,75	7,72
COP		3,13	3,20	3,02	3,19	3,07	3,18	3,10	3,18	3,19	3,06
Water flow - chiller mode	l/h	1.307	1.307	1.651	1.668	1.909	1.944	2.305	2.339	2.718	3.371
Water flow - pdc mode	l/h	1.527	1.510	1.916	1.918	2.171	2.189	2.680	2.698	3.105	4.002
DHW water flow	l/h	1.631	1.648	2.055	2.055	2.411	2.430	2.921	2.922	3.466	4.260
Pump head, system side (chiller)	kPa	142	142	125	124	121	119	142	140	128	129
Pump head, DHW side	kPa	123	122	98	98	88	86	109	108	79	94
No. of scroll compressors / circuits		1/1	1/1	1/1	1/1	1/1	1/1	1/1	1/1	1/1	1/1
Diameter of water connections	inches	1" 1/4	1" 1/4	1" 1/4	1" 1/4	1" 1/4	1" 1/4	1" 1/4	1" 1/4	1" 1/4	1" 1/4
Buffer tank	dm ³	30	30	30	30	30	30	30	30	30	50
Height	mm	1224	1224	1224	1224	1224	1224	1224	1224	1224	1273
Length	mm	1324	1324	1324	1324	1324	1324	1324	1324	1324	1665
Depth	mm	560	560	560	560	560	560	560	560	560	655
Sound power level	dB(A)	72	72	75	75	75	75	75	75	75	78
Ref. R407C	(kg)	6,3	6,3	6,3	6,3	6,5	6,5	7,4	7,4	8,3	10,8
Transport weight *	(kg)	228	228	265	265	256	256	265	265	270	393
Operating weight *	(kg)	245	245	282	282	272	272	282	282	287	426,5
MCP		027	032	040	T18M	T18	T22M	T22	T24M	T24	T30
Power supply	V-ph-Hz	400-3N-50	400-3N-50	400-3N-50	230-1-50	400-3N-50	230-1-50	400-3N-50	230-1-50	400-3N-50	400-3N-50
Cooling mode											
Cooling capacity ¹	kW	27,4	34,4	40,4	18,6	18,8	21,4	21,6	26,0	26,4	32,4
Power input 1	kW	10,00	11,92	14,74	6,72	6,52	7,75	7,55	9,79	9,29	10,73
EER		2,89	3,09	2,91	2,94	3,07	2,93	3,04	2,81	3,01	3,18
Cooling mode + ACS											
Cooling capacity ¹	kW	27,10	32,90	39,40	17,40	17,60	20,20	20,60	25,40	25,80	30,80
Power input ¹	kW	9,66	11,98	14,60	6,98	6,78	8,01	7,61	9,45	9,25	10,89
Heating capacity DHW	kW	35,65	43,45	52,42	23,48	23,49	27,23	27,25	33,76	33,97	40,49
Total COP		6,48	6,40	6,33	5,81	6,01	5,89	6,25	6,26	6,45	6,54
Heating mode (system / DHW)											
Heating capacity ²	kW	31,4	40,0	47,4	22,3	22,1	25,0	25,2	30,2	30,4	37,5
Power input ²	kW	9,90	12,52	15,04	7,52	7,32	8,55	8,35	9,99	9,79	11,53
COP		3,22	3,25	3,20	3,01	3,07	2,97	3,07	3,07	3,15	3,29
Water flow - chiller mode	l/h	4.713	5.917	6.949	3.199	3.234	3.681	3.715	4.472	4.541	5.573
Water flow - pdc mode	l/h	5.395	6.871	8.157	3.832	3.799	4.305	4.341	5.188	5.224	6.448
DHW water flow	l/h	6.132	7.473	9.015	4.039	4.040	4.684	4.687	5.807	5.843	6.964
Pump head, system side (chiller)	kPa	119	144	131	136	135	133	132	127	125	106
Pump head, DHW side	kPa	72	115	89	105	105	99	99	85	84	60
No. of scroll compressors / circuits		1/1	1/1	1/1	2/1	2/1	2/1	2/1	2/1	2/1	2/1
Diameter of water connections	inches	1" 1/4	1" 1/4	1" 1/4	1" 1/4	1" 1/4	1" 1/4	1" 1/4	1" 1/4	1" 1/4	1" 1/4
Buffer tank	dm ³	50	125	125	50	50	50	50	50	50	125
Height	mm	1273	1489	1489	1273	1273	1273	1273	1273	1273	1489
Length	mm	1665	2065	2065	1665	1665	1665	1665	1665	1665	2065
Depth	mm	655	951	951	863	863	863	863	863	863	951
Sound power level	dB(A)	78	78	78	78	78	78	78	78	78	78
Ref. R407C	(kg)	11,5	16,0	18,0	11,5	11,5	11,5	11,5	11,5	11,5	14,0
Transport weight *	(kg)	398	525	528	395	395	388,5	388,5	394	394	525
Operating weight *	(kg)	434,7	632	635	428	428	415	415	420	420	632

* Weights referred to version including pump and buffer tank

1 Water temperature 12°C - 7°C; outdoor air temperature 35°C

2 Water temperature 40°C - 45°C, outdoor air temperature 7°C dry bulb, outdoor air temperature 6°C wet bulb

Performances measured according to standard EN 14511

Multi-purpose units (ON/OFF or modulating) and heat pumps, generally speaking, are NOT suitable for use as "rapid" heaters, this means that thermal storage for the production of DHW should be provided in any case.

When reference is made to the production of domestic hot water, what is meant is the storage of thermal energy in a tank of "technical" water. Water for domestic use must be heated by means of a stainless steel coil contained inside the storage tank or a plate exchanger outside the tank; in this way it is possible to avoid storing domestic water and it is not necessary to provide for an anti-Legionella cycle (see recommended plumbing layouts for further details).

If you wish to consider the DHW storage option, the storage tank should be suitable for the storage of drinking water and equipped with a coil (connected to the multi-purpose unit) having a surface designed to allow heat exchange fit for the unit capacity, based on its working temperature and DHW storage temperatures within the storage tank.

Please note that DHW system should in no case be in contact with the water circuit of heat pumps units (a separation should always be provided).

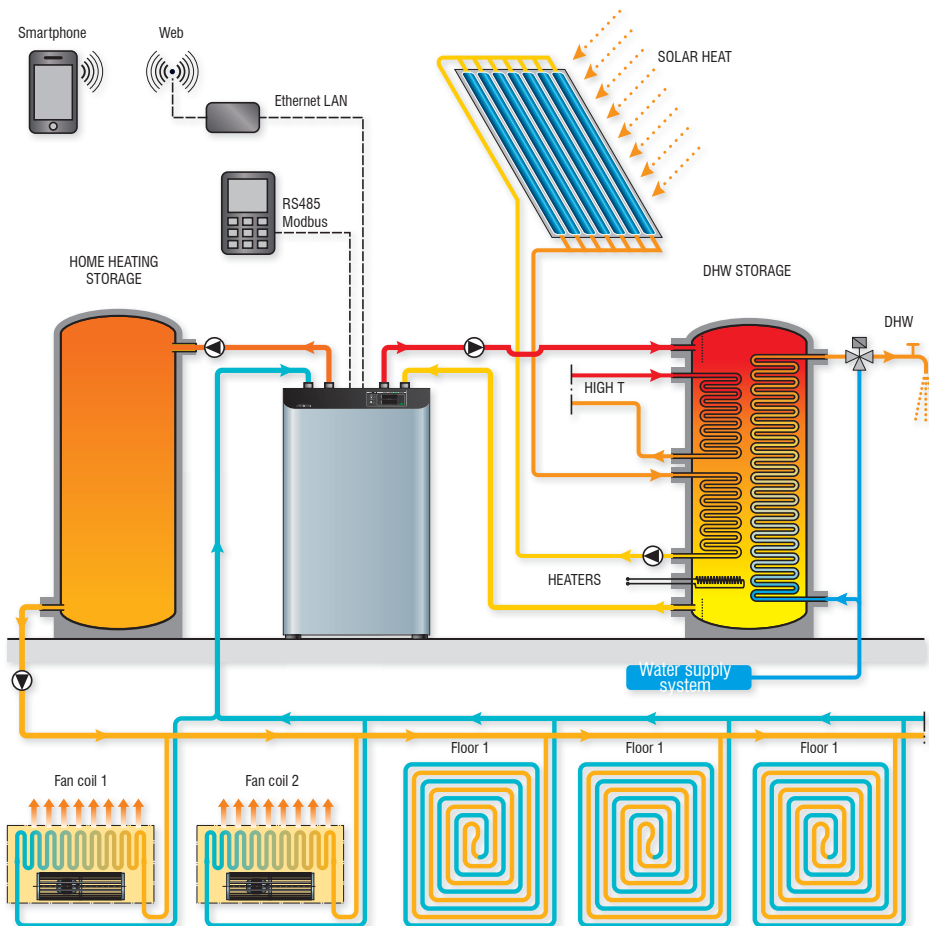

GALLETTI THERMAL STORAGE TANKS FOR THE PRODUCTION OF DHW BY CORDIVARI

Galletti introduces its new range of thermal storage tanks for the production of domestic hot water developed in partnership with Cordivari and specifically conceived for pairing with heat pumps.

This range of products combines the proven experience of Galletti in heat pumps and control logics of multi-purpose systems to the experience of Cordivari in the development of tanks.

Galletti decided to favour the thermal storage tank solution (i.e. storage of technical water within a tank) instead of the boiler solution (domestic hot water storage).

As technical water is stored, it is not necessary to provide for an anti-Legionella cycle usually carried out by means of thermal shock (causing lowering of system efficiency) or chemical treatment.

The range features two lines of products. The first one is made up of stainless steel coil for the instantaneous production of domestic warm water.

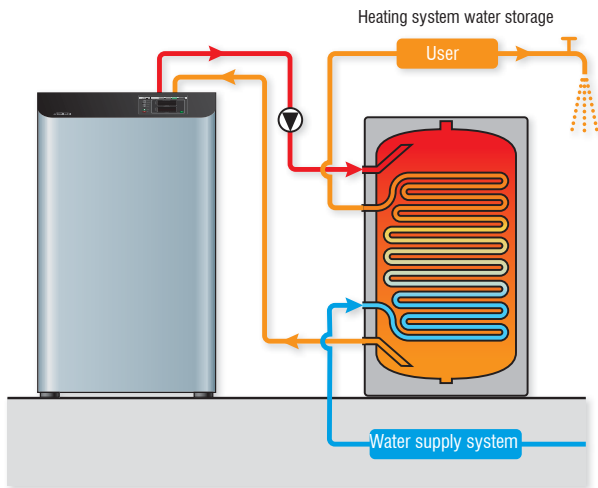

The second line of products is made up of thermal storage tanks associated with an external plate exchanger for the instantaneous production of hot water.

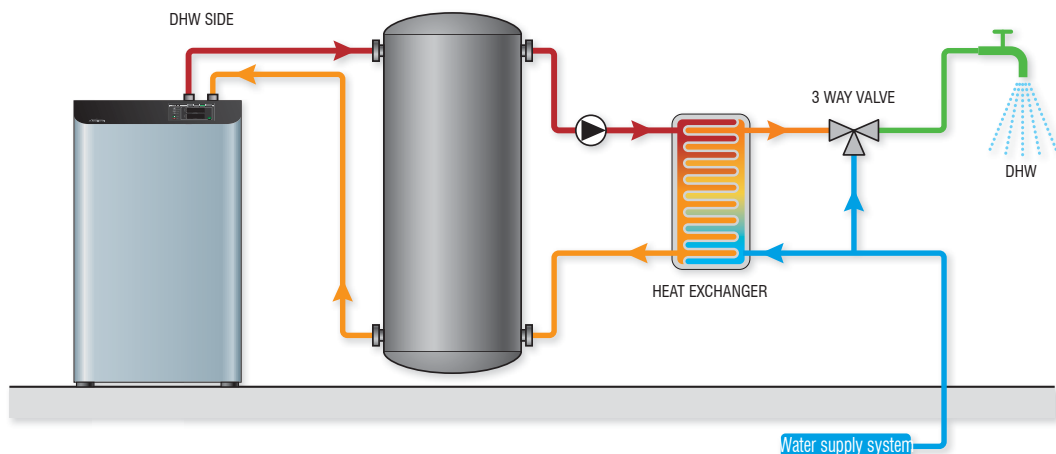

In order to develop a product that perfectly meets the requirements of multi-purpose systems installed in combination with heat pumps, Galletti and Cordivari conducted a careful study on heat exchange surfaces and stratification: the result is a range of tanks which in terms of coils and plate exchangers feature exchange surfaces that are on average much larger than those of the traditional thermal storage tanks available on the market.

The Labyrinth Diffuser (patented) has been mounted as a standard feature on all models in order to guarantee optimal stratification in all situations, including transients that may impair the storage tank performances.

All models of this range are available in a basic and a two additional coils versions as solar auxiliary system and high T source.

As part of its commitment to always improving system energy efficiency, Galletti does not use electric heating elements inside its heat pumps or tanks as auxiliary heating source.

The heating elements can be used on Galletti thermal storage tanks only as back-up in case of temporary stop of heat pump.

These thermal storage tanks are the perfect complement to the offer of multi-purpose systems by Galletti who for years has been offering MCP and HiWarm multi-purpose units.

Tank type: thermal storage tank for the production of domestic hot water

Liquid stored: water for heating system

DHW production system: stainless steel quick coil



The figure shows the connection layout of 600 and 800 litre models

CAPACITY	CODE	NET STORAGE VOLUME	DOMESTIC WATER CIRCUIT VOLUME	SURFACE AREA OF CORRUGATED COIL	WEIGHT
[l]		[l]	[l]	[m ²]	[kg]
300	RYTN 300	302,0	7,2	3,5	62
600	RYTN 600	525,8	32,2	5,5	95
800	RYTN 800	760,0	45,5	7,8	120

THERMAL STORAGE TANK		DHW COIL
Pmax	Tmax	Pmax
3 bar	99° C	6 bar

INTENDED USE

Production of domestic hot water (DHW) using “renewable” heat sources, such as heat pumps.

RYTN storage tanks are designed to store heating system water. Domestic water is made to pass inside a stainless steel corrugated coil.

Inside the thermal storage tank, at the connections used for the heat pump, there is a Labyrinth Diffuser (patented system). This element makes it possible to maintain the stratification regardless of the connection used for the inlet technical water coming from the heat pump.

NOTE: Do not use the thermal storage tank to store domestic hot water. It is recommended to use this thermal storage tank for the production of sanitary hot water only and not as auxiliary heating source on system side. In this case, the use of a dedicated tank is recommended.

MATERIALS AND FINISHES

- Thermal storage tank made of carbon steel, unfinished on the inside, painted on the outside
- 316L stainless steel corrugated coil for the domestic water circuit.

INSULATION

- For 300l size: rigid polyester foam insulating layer, thickness 70mm, with a high level of heat insulation and conductivity coefficient of 0.023W/mK.
- For 600l and 800l sizes: polyester fibre insulating layer, thickness 100 mm, with a high level of heat insulation and conductivity coefficient of 0.035 W/mK. Fire resistance class B-s2d0 according to standard EN 13501
- Grey PVC exterior coating complete with upper PVC cover

WITHDRAWAL DATA

RYTN 300	P = 0 kW		P = 5 kW		P = 10 kW		P = 15 kW	
	Q (l/min)	V (l)	Q (l/min)	V (l)	Q (l/min)	V (l)	Q (l/min)	V (l)
DHW 10C°/45C° Initial T storage 50C°	10	118	10	142	10	166	10	191
	20	83	20	91	20	100	20	108
	30	48	30	51	30	54	30	57
DHW 10C°/45C° Initial T storage 50C°	10	96	10	116	10	135	10	155
	20	67	20	74	20	81	20	88
	30	39	30	42	30	44	30	47

RYTN 600	P = 0 kW		P = 5 kW		P = 10 kW		P = 15 kW		P = 20 kW		P = 25 kW	
	Q (l/min)	V (l)	Q (l/min)	V (l)	Q (l/min)	V (l)	Q (l/min)	V (l)	Q (l/min)	V (l)	Q (l/min)	V (l)
DHW 10C°/45C° Initial T storage 50C°	10	293	10	353	10	413	10	473	10	533	10	593
	20	223	20	246	20	269	20	291	20	314	20	337
	30	153	30	163	30	174	30	184	30	195	30	205
DHW 10C°/45C° Initial T storage 50C°	10	240	10	289	10	338	10	387	10	436	10	485
	20	182	20	201	20	220	20	238	20	257	20	276
	30	125	30	134	30	142	30	151	30	159	30	168

RYTN 800	P = 0 kW		P = 15 kW		P = 20 kW		P = 25 kW		P = 30 kW		P = 35 kW	
	Q (l/min)	V (l)	Q (l/min)	V (l)	Q (l/min)	V (l)	Q (l/min)	V (l)	Q (l/min)	V (l)	Q (l/min)	V (l)
DHW 10C°/45C° Initial T storage 50C°	10	469	10	757	10	853	10	949	10	1045	10	1141
	20	367	20	480	20	517	20	555	20	592	20	630
	30	266	30	320	30	339	30	357	30	375	30	393
DHW 10C°/45C° Initial T storage 50C°	10	384	10	619	10	698	10	777	10	855	10	934
	20	300	20	392	20	423	20	454	20	485	20	515
	30	218	30	262	30	277	30	292	30	307	30	322

Q = flow rate of domestic hot water withdrawn from the coil in l/min
 P = power in kW of the connected heat pump under the conditions considered (e.g. outdoor T)
 V = maximum quantity of DHW that can be produced under the specified conditions

RYTN 300

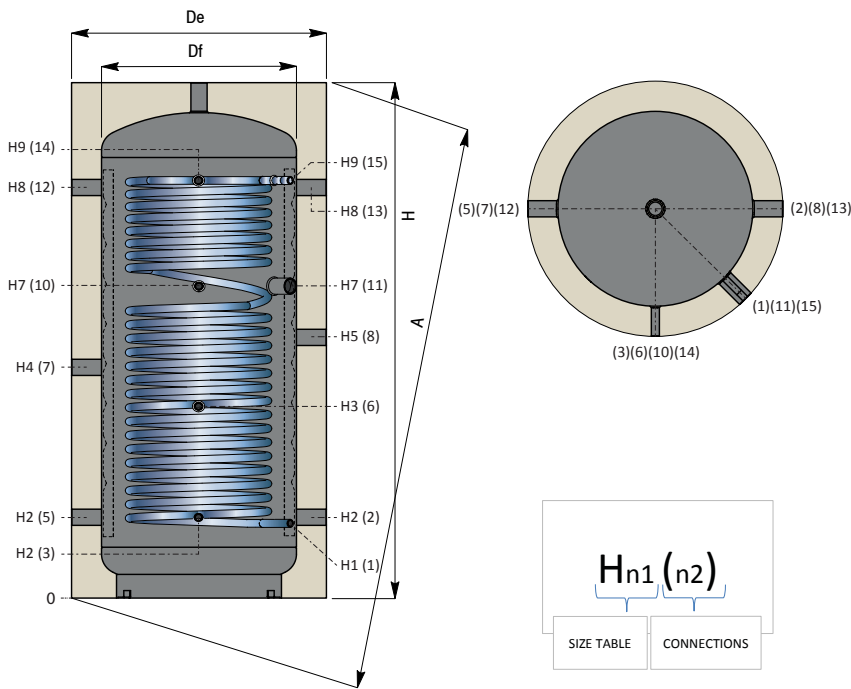

CONNECTIONS	
1	Domestic water inlet - 1" Gas M
2-5	Return to heat pump
3	Probe - 1/2" Gas F
6	Probe - 1/2" Gas F
7	Inlet for heating system water from heat pump* - 1"1/2 Gas F
8	Return to Generator* - 1"1/2 Gas F
10	Probe - 1/2" Gas F
11	Backup heating element - 1"1/2 Gas F
12-13	Inlet for heating system water from heat pump / from Generator* - 1"1/2 Gas F
14	Probe - 1/2" Gas F
15	Domestic water outlet - 1" Gas F

* in the presence of a second high temperature generator that works directly on the upper part of the storage tank

It is recommended not to use the connection on the top of tank for the delivery from a heat pump or a high temperature generator to avoid any stratification spoiling.

It is recommended to use this thermal storage tank for the production of sanitary hot water only and not as auxiliary heating source on system side. In this case, the use of a dedicated tank is recommended.

RYTN 600 - RYTN 800

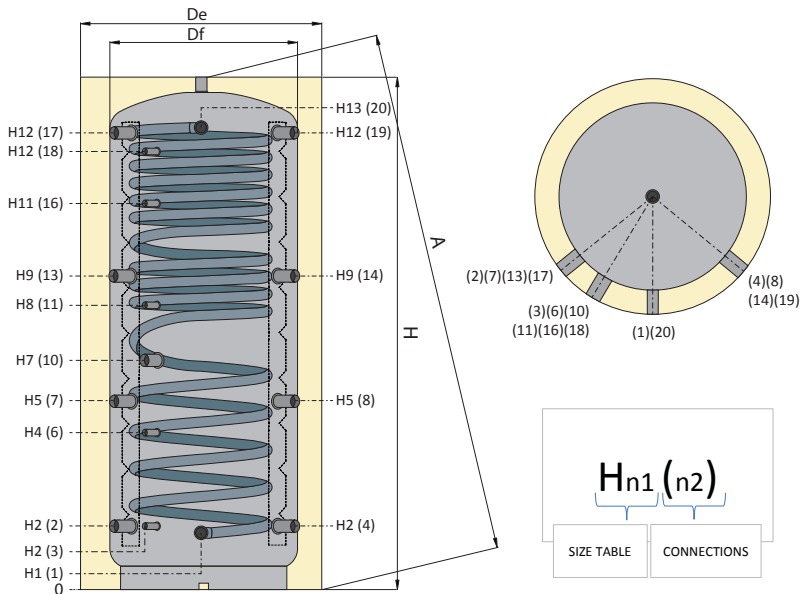

CONNECTIONS	
1	Domestic water inlet - 1" Gas M
2-4	Return to heat pump
3	Probe - 1/2" Gas F
6	Probe - 1/2" Gas F
7-8	Inlet for heating system water from heat pump* - 1"1/2 Gas F
10	Backup heating element - 1"1/2 Gas F
11	Probe - 1/2" Gas F
13-14	Return to Generator* - 1"1/2 Gas F
16	Probe - 1/2" Gas F
17-19	Inlet for heating system water from heat pump / from Generator* - 1"1/2 Gas F
18	Probe - 1/2" Gas F
20	Domestic water outlet - 1" Gas M

* in the presence of a second high temperature generator that works directly on the upper part of the storage tank

It is recommended not to use the connection on the top of tank for the delivery from a heat pump or a high temperature generator to avoid any stratification spoiling.

It is recommended to use this thermal storage tank for the production of sanitary hot water only and not as auxiliary heating source on system side. In this case, the use of a dedicated tank is recommended.

SIZE TABLE

Capacity	Df	De	H	A	H1	H2	H3	H4	H5	H6	H7	H8	H9	H10	H11	H12	H13
[litres]	[mm]																
300	550	690	1521	1670	233	266	581	766	866	-	906	1216	1251	-	-	-	-
600	650	850	1920	1945	230	247	-	582	695	-	915	1060	1144	-	1382	1593	1610
800	790	990	1890	1925	248	265	-	584	690	-	838	988	1115	-	1332	1541	1558

This series of thermal storage tanks, fruit of a partnership combining the experience of Galletti and Cordivari, was specifically conceived for pairing with heat pumps.

Storage type: thermal storage tank for the production of domestic hot water

Liquid stored: water for heating system

DHW production system: stainless steel quick coil

Additional coils: a solar thermal coil and high temperature coil

CAPACITY	CODE	NET STORAGE VOLUME	DOMESTIC WATER CIRCUIT VOLUME	SURFACE AREA OF CORRUGATED COIL	VOLUME OF LOWER FIXED COIL	SURFACE AREA OF LOWER FIXED COIL	VOLUME OF UPPER FIXED COIL	SURFACE AREA OF UPPER FIXED COIL	WEIGHT
[l]		[l]	[l]	[m ²]	[l]	[m ²]	[l]	[m ²]	[kg]
300	RYTNSH 300	288,3	7,2	3,5	7,8	1,2	5,9	0,9	85
600	RYTNSH 600	501,8	32,2	5,5	13	2	8	1,25	132
800	RYTNSH 800	728	45,5	7,8	16,3	2,5	11,8	1,8	169

THERMAL STORAGE TANK		DHW COIL	SOLAR AND HIGH TEMPERATURE COIL	
Pmax	Tmax	Pmax	Pmax	Pmax
3 bar	99° C	6 bar	12 bar	110° C

INTENDED USE

Production of domestic hot water (DHW) using “renewable” heat sources, such as heat pumps.

RYTNSH thermal storage tanks are provided with additional charging coils to enable use of heat originating from solar thermal panels or other high temperature sources of heat such as, for example, fireplace heaters, biomass generators, etc.

Inside the thermal storage tank, at the connections used for the heat pump, there is a Labyrinth Diffuser (patented system). This element makes it possible to maintain the stratification regardless of the connection used for the inlet technical water coming from the heat pump.

NOTE: RYTNSH storage tanks are designed to store solely heating system water. Domestic water is made to pass inside a stainless steel corrugated coil. Do not use the thermal storage tank to store domestic hot water.

MATERIALS AND FINISHES

- Thermal storage tank made of carbon steel, unfinished on the inside, painted on the outside

- 316L stainless steel corrugated coil for the domestic water circuit.

WITHDRAWAL DATA*

RYTNSH 300	P = 0 kW		P = 5 kW		P = 10 kW		P = 15 kW	
	Q (l/min)	V (l)	Q (l/min)	V (l)	Q (l/min)	V (l)	Q (l/min)	V (l)
DHW 10C°/45C° Initial T storage 50C°	10	118	10	142	10	166	10	191
	20	83	20	91	20	100	20	108
	30	48	30	51	30	54	30	57
DHW 10C°/45C° Initial T storage 50C°	10	96	10	116	10	135	10	155
	20	67	20	74	20	81	20	88
	30	39	30	42	30	44	30	47

RYTNSH 600	P = 0 kW		P = 5 kW		P = 10 kW		P = 15 kW		P = 20 kW		P = 25 kW	
	Q (l/min)	V (l)	Q (l/min)	V (l)	Q (l/min)	V (l)	Q (l/min)	V (l)	Q (l/min)	V (l)	Q (l/min)	V (l)
DHW 10C°/45C° Initial T storage 50C°	10	293	10	353	10	413	10	473	10	533	10	593
	20	223	20	246	20	269	20	291	20	314	20	337
	30	153	30	163	30	174	30	184	30	195	30	205
DHW 10C°/45C° Initial T storage 50C°	10	240	10	289	10	338	10	387	10	436	10	485
	20	182	20	201	20	220	20	238	20	257	20	276
	30	125	30	134	30	142	30	151	30	159	30	168

RYTNSH 800	P = 0 kW		P = 15 kW		P = 20 kW		P = 25 kW		P = 30 kW		P = 35 kW	
	Q (l/min)	V (l)	Q (l/min)	V (l)	Q (l/min)	V (l)	Q (l/min)	V (l)	Q (l/min)	V (l)	Q (l/min)	V (l)
DHW 10C°/45C° Initial T storage 50C°	10	469	10	757	10	853	10	949	10	1045	10	1141
	20	367	20	480	20	517	20	555	20	592	20	630
	30	266	30	320	30	339	30	357	30	375	30	393
DHW 10C°/45C° Initial T storage 50C°	10	384	10	619	10	698	10	777	10	855	10	934
	20	300	20	392	20	423	20	454	20	485	20	515
	30	218	30	262	30	277	30	292	30	307	30	322

Q = flow rate of domestic hot water withdrawn from the coil in l/min

P = power in kW of the connected heat pump under the conditions considered (e.g. outdoor T)

V = maximum quantity of DHW that can be produced under the specified conditions

* withdrawal data refer only to the use of heat pump and not to a solar thermal source or other high temperature sources.



The figure shows the connection layout of 600 and 800 litre models



It is recommended to use this thermal storage tank for the production of sanitary hot water only and not as auxiliary heating source on system side. In this case, the use of a dedicated tank is recommended.

RYTNSH 300

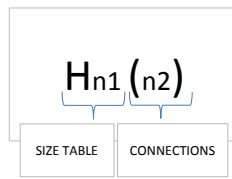
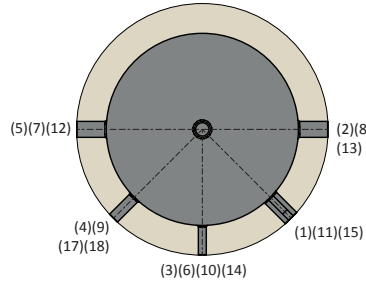
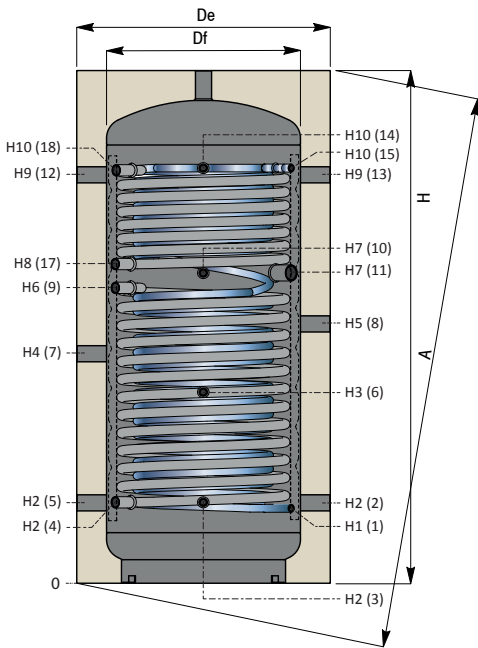

CONNECTIONS	
1	Domestic water inlet - 1/2" Gas F
2-5	Return to heat pump - 1"1/2 Gas F
3	Probe - 1/2" Gas F
4	Lower fixed coil outlet - 1" Gas F
6	Probe - 1/2" Gas F
7	Inlet for heating system water from heat pump* - 1"1/2 Gas F
8	Return to Generator* - 1"1/2 Gas F
9	Lower fixed coil outlet - 1" Gas F
10	Probe - 1/2" Gas F
11	Backup heating element - 1"1/2 Gas F
12-13	Inlet for heating system water from heat pump / from Generator* - 1"1/2 Gas F
14	Probe - 1/2" Gas F
15	Domestic water outlet - 1/2" Gas F
17	Upper fixed coil outlet - 1" Gas F
18	Upper fixed coil inlet - 1" Gas F

* in the presence of a second high temperature generator that works directly on the upper part of the storage tank

RYTNSH 600 - RYTNSH 800

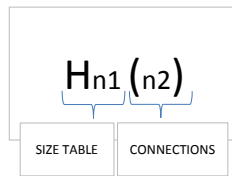
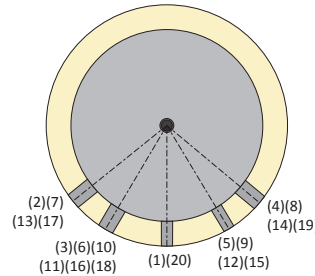
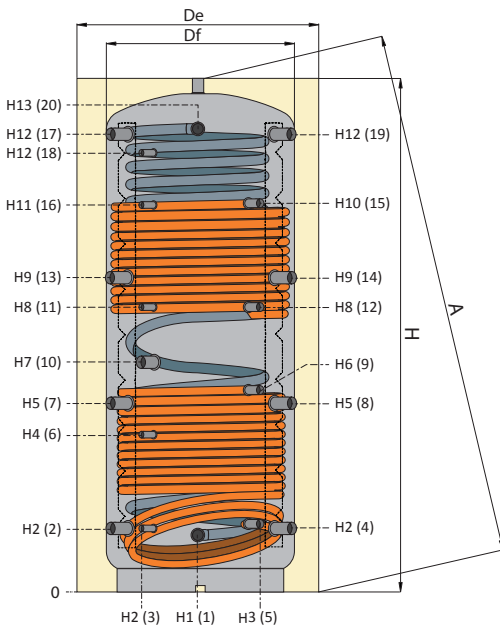

CONNECTIONS	
1	Domestic water inlet - 1" Gas M
2-4	Return to heat pump - 1"1/2 Gas F
3	Probe - 1/2" Gas F
5	Lower fixed coil outlet - 1" Gas F
6	Probe - 1/2" Gas F
7-8	Inlet for heating system water to heat pump* - 1"1/2 Gas F
9	Lower fixed coil outlet - 1" Gas F
10	Backup heating element - 1"1/2 Gas F
11	Probe - 1/2" Gas F
12	Upper fixed coil outlet - 1" Gas F
13-14	Return to Generator* - 1"1/2 Gas F
15	Upper fixed coil inlet - 1" Gas F
16	Probe - 1/2" Gas F
17-19	Inlet for heating system water from heat pump / from Generator* - 1"1/2 Gas F
18	Probe - 1/2" Gas F
20	Domestic water outlet - 1" Gas M

* in the presence of a second high temperature generator that works directly on the upper part of the storage tank

It is recommended not to use the connection on the top of tank for the delivery from a heat pump or a high temperature generator to avoid any stratification spoiling.

SIZE TABLE

Capacity	Df	De	H	A	H1	H2	H3	H4	H5	H6	H7	H8	H9	H10	H11	H12	H13
[litres]	[mm]																
300	550	690	1521	1579	233	266	581	766	866	806	976	906	1216	1251	-	-	-
600	650	850	1920	1945	230	247	260	582	695	855	915	1060	1144	1361	1382	1593	1610
800	790	990	1890	1925	248	265	278	584	690	762	823	988	1115	1332	1332	1541	1558

This series of thermal storage tanks, fruit of a partnership combining the experience of Galletti and Cordivari, was specifically conceived for pairing with heat pumps.

Tank type: thermal storage tank for the production of domestic hot water

Liquid stored: water for heating system

Method of DHW production: external module with stainless steel plate heat exchanger



RYTP Series

CAPACITY	CODE	NET STORAGE VOLUME	MAX POWER OF DHW MODULE	WEIGHT
[l]		[l]	kW	[kg]
300	RYTP 300	286	120*	106
500	RYTP 500	505	120*	131
800	RYTP 800	803	120*	152

* = maximum power referred to a storage temperature of 80°C

THERMAL STORAGE TANK		STAINLESS STEEL PLATE HEAT EXCHANGER	
Pmax	Tmax	Pmax	Tmax
3 bar	99° C	6 bar	99° C

INTENDED USE

Production of domestic hot water (DHW) using “renewable” heat sources, such as heat pumps.

RYTP storage tanks are designed to store heating system water. Domestic water is made to pass inside a stainless steel plate heat exchanger.

NOTE: RYTP storage tanks are designed to store solely heating system water. Do not use the thermal storage tank to store domestic hot water.

MATERIALS AND FINISHES

Thermal storage tank made of carbon steel, unfinished on the inside, painted on the outside.

Heat exchanger: external module with a 316L stainless steel plate heat exchanger for the production of domestic hot water

INSULATION

- Polyester fibre insulating layer, thickness 100 mm, with a high level of heat insulation and conductivity coefficient of 0.035 W/mK Fire resistance class B-s2d0 according to standard EN 13501
- Grey PVC exterior coating complete with upper PVC cover
- External module clad in painted sheet metal and insulated on the inside

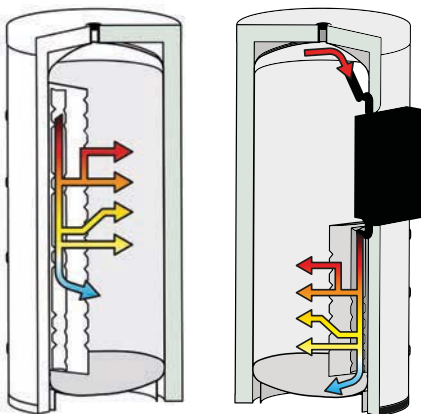

- **Thermal storage tank:** reservoir of heating system water acting as a thermal flywheel. Inside the thermal storage tank there are a labyrinth diffuser (patented system) on the DHW module and two other labyrinth diffusers on both sides of the tank which ensure perfect stratification of technical inlet water coming from the heat pump and of technical outlet water at the instantaneous production module output. The labyrinth diffuser is located on both sides of the storage tank and is arranged so as to make it possible to maintain the stratification regardless of the connection used for the inlet technical water coming from the heat pump.

- **DHW production module:** an external unit that instantly heats domestic water by exploiting the heat stored in the puffer, ensuring hygiene and comfort as well as the possibility of regulating the outlet temperature. The module consists of a stainless steel plate exchanger, an on/off pump and a 3-way valve for temperature-controlled pre-mixing on the exchanger inlet (primary side), which prevents excessively high temperatures in the exchanger itself while considerably reducing the risk of limescale build-up.

WITHDRAWAL DATA

RYTP 300	P = 0 kW		P = 5 kW		P = 10 kW		P = 15 kW		P = 20 kW		P = 25 kW	
	Q (l/min)	V (l)	Q (l/min)	V (l)	Q (l/min)	V (l)	Q (l/min)	V (l)	Q (l/min)	V (l)	Q (l/min)	V (l)
DHW 10C°/45C° Initial T storage 50C°	10	334	10	420	10	566	10	866	10	1846	10	infinite
	20	334	20	372	20	420	20	482	20	566	20	684
	26,3	334*	26,3	362*	26,3	396*	26,3	436*	26,3	485*	26,3	547*
DHW 10C°/45C° Initial T storage 50C°	10	264	10	332	10	447	10	684	10	1459	10	infinite
	20	264	20	294	20	332	20	381	20	447	20	541
	21	264	21	293	21	328	21	373	21	433	21	515

Q = flow rate of domestic hot water withdrawn from the coil in l/min
 P = power in kW of the connected heat pump under the conditions considered (e.g. outdoor T)
 V = maximum quantity of DHW that can be produced under the specified conditions
 * = DHW outlet temperature 42.6 °C

WITHDRAWAL DATA

RYTP 500	P = 0 kW		P = 15 kW		P = 20 kW		P = 25 kW		P = 30 kW		P = 35 kW	
	Q (l/min)	V (l)	Q (l/min)	V (l)	Q (l/min)	V (l)	Q (l/min)	V (l)	Q (l/min)	V (l)	Q (l/min)	V (l)
DHW 10C°/45C° Initial T storage 50C°	10	557	10	1444	10	3078	10	infinite	10	infinite	10	infinite
	20	557	20	804	20	943	20	1141	20	1444	20	1966
	26,3	557	26,3	727	26,3	809	26,3	912	26,3	1045	26,3	1224
DHW 10C°/45C° Initial T storage 50C°	10	441	10	1143	10	2437	10	infinite	10	infinite	10	infinite
	20	441	20	636	20	747	20	904	20	1143	20	1556
	21	441	21	623	21	723	21	861	21	1063	21	1389

RYTP 800	P = 0 kW		P = 15 kW		P = 20 kW		P = 25 kW		P = 30 kW		P = 35 kW	
	Q (l/min)	V (l)	Q (l/min)	V (l)	Q (l/min)	V (l)	Q (l/min)	V (l)	Q (l/min)	V (l)	Q (l/min)	V (l)
DHW 10C°/45C° Initial T storage 50C°	10	891	10	2310	10	4924	10	infinite	10	infinite	10	infinite
	20	891	20	1286	20	1509	20	1825	20	231	20	3145
	26,3	891	26,3	1163	26,3	1294	26,3	1459	26,3	1672	26,3	1958
DHW 10C°/45C° Initial T storage 50C°	10	705	10	1828	10	3896	10	infinite	10	infinite	10	infinite
	20	705	20	1018	20	1194	20	1444	20	1828	20	2488
	21	705	21	996	21	1156	21	1376	21	1699	21	2221

Q = flow rate of domestic hot water withdrawn from the coil in l/min
P = power in kW of the connected heat pump under the conditions considered (e.g. outdoor T)
V = maximum quantity of DHW that can be produced under the specified conditions
 * = DHW outlet temperature 42.6 °C

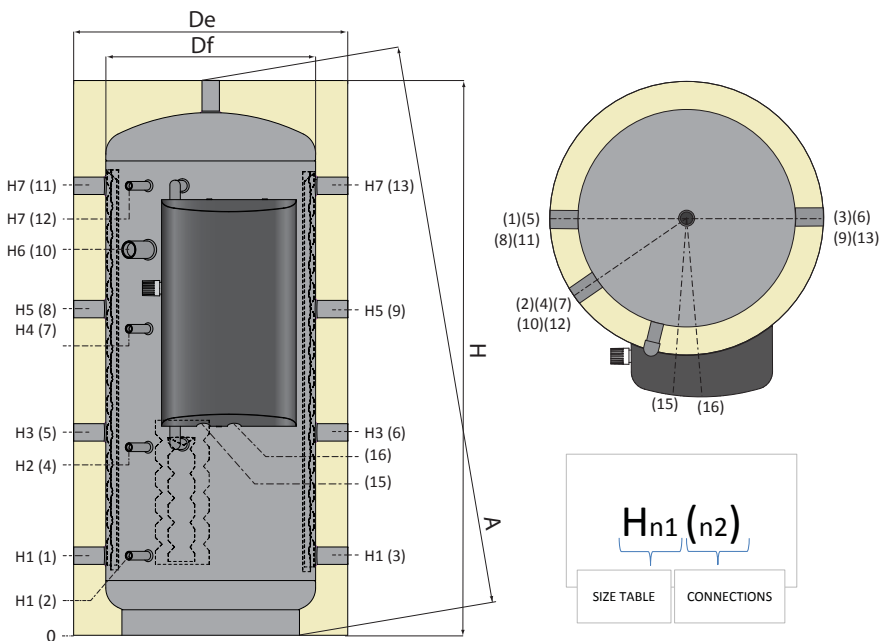

CONNECTIONS	
1-3	Return to heat pump - 1"1/2 Gas F
2	Probe - 1/2" Gas F
4	Probe - 1/2" Gas F
5-6	Inlet for water from heat pump* - 1"1/2 Gas F
7	Probe - 1/2" Gas F
8-9	Return to Generator* - 1"1/2 Gas F
10	Backup heating element - 1"1/2 Gas F
11-13	Inlet for water from heat pump / from Generator* - 1"1/2 Gas F
12	Probe - 1/2" Gas F
15	DHW outlet - 1" Gas M
16	DHW inlet - 1" Gas M

* in the presence of a second high temperature generator that works directly on the upper part of the storage tank

It is recommended not to use the connection on the top of tank for the delivery from a heat pump or a high temperature generator to avoid any stratification spoiling.

It is recommended to use this thermal storage tank for the production of sanitary hot water only and not as auxiliary heating source on system side. In this case, the use of a dedicated tank is recommended.

SIZE TABLE

Capacity	Df	De	H	A	H1	H2	H3	H4	H5	H6	H7
[litres]	[mm]										
300	550	750	1360	1374	232	425	497	625	782	855	1048
500	650	850	1719	1737	247	583	629	950	1011	1195	1393
800	790	990	1888	1915	265	613	690	1038	1115	1338	1541

This series of thermal storage tanks, fruit of a partnership combining the experience of Galletti and Cordivari, was specifically conceived for pairing with heat pumps.

Tank type: thermal storage tank for the production of domestic hot water

Liquid stored: water for heating system

Method of DHW production: external module with stainless steel plate heat exchanger

Additional coils: a solar thermal coil and high temperature coil

CAPACITY	CODE	NET STORAGE VOLUME	MAX POWER OF DHW MODULE	VOLUME OF LOWER FIXED COIL	SURFACE AREA OF LOWER FIXED COIL	VOLUME OF UPPER FIXED COIL	SURFACE AREA OF UPPER FIXED COIL	WEIGHT
[l]		[l]	kW	[l]	[m ²]	[l]	[m ²]	[kg]
300	RYTPSH 300	278,1	120*	7,6	1,2	4,4	0,7	125
500	RYTPSH 500	483,1	120*	13,5	2,1	6,5	1,25	170
800	RYTPSH 800	774,9	120*	16,3	2,5	13,5	1,8	202

* =maximum power referred to a storage temperature of 80°C

THERMAL STORAGE TANK		SOLAR AND HIGH T. COIL		STAINLESS STEEL PLATE HEAT EXCHANGER	
Pmax	Tmax	Pmax	Tmax	Pmax	Tmax
3 bar	99° C	12 bar	110° C	6 bar	99° C

INTENDED USE

Production of domestic hot water (DHW) using “renewable” heat sources, such as heat pumps. RYTPSH storage tanks are designed to store heating system water. Domestic water is made to pass inside a stainless steel plate heat exchanger.

RYTPSH thermal storage tanks are provided with additional charging coils to enable use of heat originating from solar thermal panels or other sources of heat such as, for example, fireplace heaters, biomass generators, etc.

NOTE: RYTPSH storage tanks are designed to store solely heating system water. Do not use the thermal storage tank to store domestic hot water.

MATERIALS AND FINISHES

Thermal storage tank made of carbon steel, unfinished on the inside, painted on the outside.

Heat exchanger: external module with a 316L stainless steel plate

heat exchanger for the production of domestic hot water

INSULATION

- Polyester fibre insulating layer, thickness 100 mm, with a high level of heat insulation and conductivity coefficient of 0.035 W/mK Fire resistance class B-s2d0 according to standard EN 13501
- Grey PVC exterior coating complete with upper PVC cover
- External module clad in painted sheet metal and insulated on the inside.

HEAT EXCHANGERS

2 fixed carbon steel coils for solar thermal and high temperatures



The figure shows the connection layout of 500 and 800 litre models

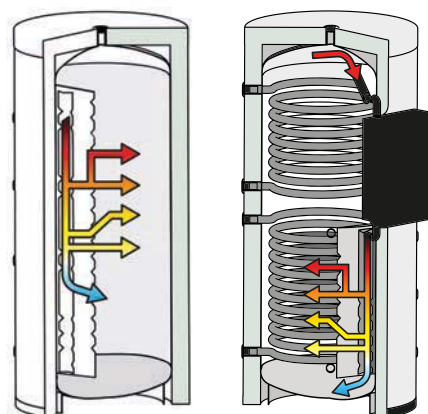

- **Thermal storage tank:** reservoir of heating system water acting as a thermal flywheel. Inside the thermal storage tank there are a labyrinth diffuser (patented system) on the DHW module and two other labyrinth diffusers on both sides of the tank which ensure perfect stratification of technical inlet water coming from the heat pump and of technical outlet water at the instantaneous production module output. The labyrinth diffuser is located on both sides of the storage tank and is arranged so as to make it possible to maintain the stratification regardless of the connection used for the inlet technical water coming from the heat pump.

- **DHW production module:** an external unit that instantly heats domestic water by exploiting the heat stored in the puffer, ensuring hygiene and comfort as well as the possibility of regulating the outlet temperature. The module consists of a stainless steel plate exchanger, an on/off pump and a 3-way valve for temperature-controlled pre-mixing on the exchanger inlet (primary side), which prevents excessively high temperatures in the exchanger itself while considerably reducing the risk of limescale build-up.

WITHDRAWAL DATA**

RYTPSH 300	P = 0 kW		P = 5 kW		P = 10 kW		P = 15 kW		P = 20 kW		P = 25 kW	
	Q (l/min)	V (l)	Q (l/min)	V (l)	Q (l/min)	V (l)	Q (l/min)	V (l)	Q (l/min)	V (l)	Q (l/min)	V (l)
DHW 10C°/45C° Initial T storage 50C°	10	334	10	420	10	566	10	866	10	1846	10	infinite
	20	334	20	372	20	420	20	482	20	566	20	684
	26,3	334*	26,3	362*	26,3	396*	26,3	436*	26,3	485*	26,3	547*
DHW 10C°/45C° Initial T storage 50C°	10	264	10	332	10	447	10	684	10	1459	10	infinite
	20	264	20	294	20	332	20	381	20	447	20	541
	21	264	21	293	21	328	21	373	21	433	21	515

Q = flow rate of domestic hot water withdrawn from the coil in l/min

P = power in kW of the connected heat pump under the conditions considered (e.g. outdoor T)

V = maximum quantity of DHW that can be produced under the specified conditions

* = DHW outlet temperature 42.6 °C

** withdrawal data refer only to the use of heat pump and not to a solar thermal source or other high temperature sources.

WITHDRAWAL DATA**

RYTPSH 500	P = 0 kW		P = 15 kW		P = 20 kW		P = 25 kW		P = 30 kW		P = 35 kW	
	Q (l/min)	V (l)	Q (l/min)	V (l)	Q (l/min)	V (l)	Q (l/min)	V (l)	Q (l/min)	V (l)	Q (l/min)	V (l)
DHW 10C°/45C° Initial T storage 50C°	10	557	10	1444	10	3078	10	infinite	10	infinite	10	infinite
	20	557	20	804	20	943	20	1141	20	1444	20	1966
	26,3	557	26,3	727	26,3	809	26,3	912	26,3	1045	26,3	1224
DHW 10C°/45C° Initial T storage 50C°	10	441	10	1143	10	2437	10	infinite	10	infinite	10	infinite
	20	441	20	636	20	747	20	904	20	1143	20	1556
	21	441	21	623	21	723	21	861	21	1063	21	1389

RYTPSH 800	P = 0 kW		P = 15 kW		P = 20 kW		P = 25 kW		P = 30 kW		P = 35 kW	
	Q (l/min)	V (l)	Q (l/min)	V (l)	Q (l/min)	V (l)	Q (l/min)	V (l)	Q (l/min)	V (l)	Q (l/min)	V (l)
DHW 10C°/45C° Initial T storage 50C°	10	891	10	2310	10	4924	10	infinite	10	infinite	10	infinite
	20	891	20	1286	20	1509	20	1825	20	231	20	3145
	26,3	891	26,3	1163	26,3	1294	26,3	1459	26,3	1672	26,3	1958
DHW 10C°/45C° Initial T storage 50C°	10	705	10	1828	10	3896	10	infinite	10	infinite	10	infinite
	20	705	20	1018	20	1194	20	1444	20	1828	20	2488
	21	705	21	996	21	1156	21	1376	21	1699	21	2221

Q = flow rate of domestic hot water withdrawn from the coil in l/min

P = power in kW of the connected heat pump under the conditions considered (e.g. outdoor T)

V = maximum quantity of DHW that can be produced under the specified conditions

* = DHW outlet temperature 42.6 °C

** withdrawal data refer only to the use of heat pump and not to a solar thermal source or other high temperature sources.

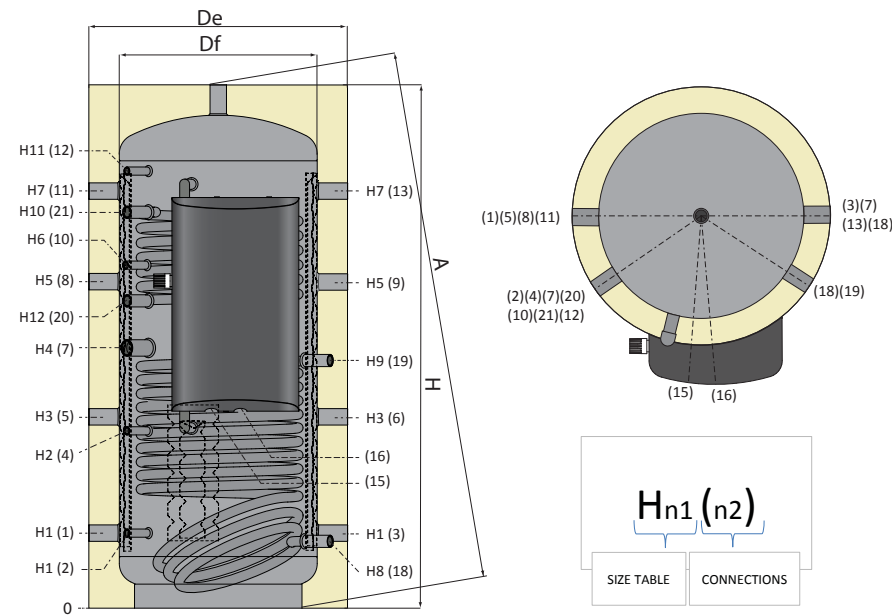

CONNECTIONS	
1-3	Return to heat pump - 1"1/2 Gas F
2	Probe - 1/2" Gas F
4	Probe - 1/2" Gas F
5-6	Inlet for water from heat pump* - 1"1/2 Gas F
7	Backup heating element - 1"1/2 Gas F
8-9	Return to Generator* - 1"1/2 Gas F
10	Probe - 1/2" Gas F
11-13	Inlet for water from heat pump / from Generator* - 1"1/2 Gas F
12	Probe - 1/2" Gas F
15	DHW outlet - 1" Gas M
16	DHW inlet - 1" Gas M
18	Lower fixed coil outlet - 1" Gas F
19	Lower fixed coil outlet - 1" Gas F
20	Upper fixed coil outlet - 1" Gas F
21	Upper fixed coil inlet - 1" Gas F

* in the presence of a second high temperature generator that works directly on the upper part of the storage tank

It is recommended not to use the connection on the top of tank for the delivery from a heat pump or a high temperature generator to avoid any stratification spoiling.

It is recommended to use this thermal storage tank for the production of sanitary hot water only and not as auxiliary heating source on system side. In this case, the use of a dedicated tank is recommended.

SIZE TABLE

Capacity	Df	De	H	A	H1	H2	H3	H4	H5	H6	H7	H8	H9	H10	H11	H12
[litres]	[mm]															
300	550	750	1360	1374	232	425	497	645	762	870	1048	195	604	1002	1085	762
500	650	850	1719	1737	247	583	629	904	1011	1124	1393	220	814	1301	1393	1011
800	790	990	1888	1915	265	613	690	898	1115	1138	1541	265	749	1428	1138	1020

This series of thermal storage tanks, fruit of a partnership combining the experience of Galletti and Cordivari, was specifically conceived for pairing with heat pumps.

* Check in table 1 the coupling of heating element and DHW production tank

	RYR02M	RYR03M	RYR06T	RYR12T
RYTN300	✓	✓	-	-
RYTN600	✓	✓	✓	-
RYTN800	✓	✓	✓	✓
RYTNSH300	✓	✓	-	-
RYTNSH600	✓	✓	✓	-
RYTNSH800	✓	✓	✓	✓
RYTP300	✓	✓	-	-
RYTP500	✓	✓	✓	-
RYTP800	✓	✓	✓	✓
RYTPSH300	✓	✓	-	-
RYTPSH500	✓	✓	✓	-
RYTPSH800	✓	✓	✓	✓

Table 1 - Tank - heating elements combinations

TOTAL HEAT RECOVERY MULTI-PURPOSE REVERSIBLE AIR/WATER HEAT PUMPS

- > HEATING
- > AIR CONDITIONING
- > COOLING
- > DEHUMIDIFICATION
- > DOMESTIC HOT WATER
- > 2 AND 4 PIPES SYSTEMS
- > MAXIMUM ENERGY EFFICIENCY
- > TOTAL HEAT RECOVERY
- > INTEGRATED HYDRONIC SYSTEM
- > SMART DEFROST SYSTEM

LCP multifunctional units are air conditioning and domestic hot water (DHW) production units conceived for both residential and industrial use and designed to operate 24 hours a day.

They cover a wide range of heating capacities, from 50 to 370 kW, guaranteeing a high thermodynamic efficiency and broad configurability, both in terms of accessories and cooling circuits.

All units of the LCP series, regardless of size, can be made in a standard configuration "S" or a low-noise configuration "L", in which the compressors and compressor compartment are covered with sound-deadening material and the unit is specially dimensioned so as to be compatible with a reduced fan speed.

All units of the LCP series, regardless of size, can be coupled with both 2- and 4-pipe systems; the letter "P" indicates heat pump with total recovery for 4-pipe systems and the letter "M" indicates multifunctional heat pump for 2-pipe systems.

The LCP units are identified by the following code:

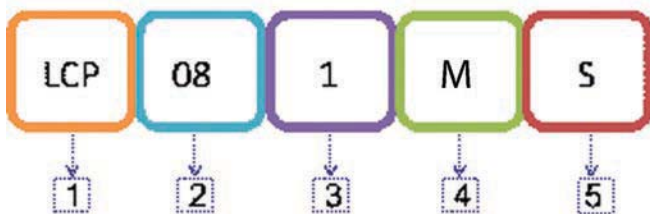

- 1 Initials identifying the Galletti model (example: "LCP" unit)
- 2 Unit size expressed in rated cooling capacity x10 [kW] (example: 08 ≥ 80 kW)
- 3 Efficiency Pack: layout of cooling circuit and compressors (example: Efficiency Pack 1)
- 4 Unit version (example: "H", Multifunctional)
- 5 Unit configuration (example: "S", optional sound insulation not present)

LCP multifunctional units have 4 water connections for two different plumbing circuits for 2- or 4-pipe systems:

Circuit 1, production of chilled water (or hot water if the unit is reversible like LCP M)

Circuit 2, production of hot water through total heat recovery



Schematic illustration of the operating modes available for an **LCP M** which interfaces with a 2-pipe air conditioning system and guarantees the production of hot or cold water on the primary side and the simultaneous production of hot water on the total recovery side.

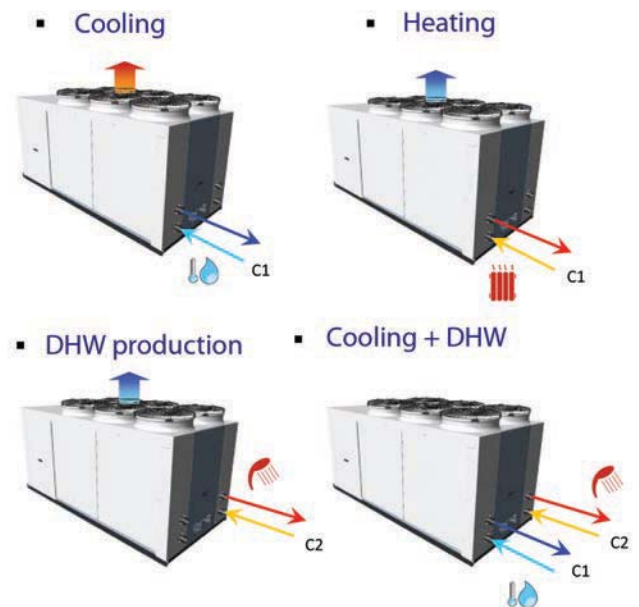

Schematic illustration of the operating modes available for an **LCP P** unit which interfaces with a 4-pipe heating/air conditioning system and guarantees the simultaneous production of hot and cold water

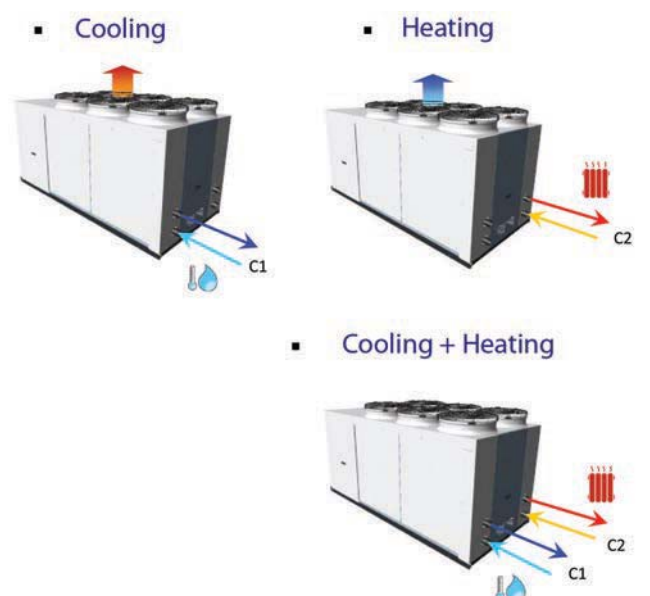

OPERATING MODES OF LCP M TOTAL HEAT RECOVERY MULTI-PURPOSE UNITS

Cooling

In the “Chiller” mode the LCP M multifunctional unit chills water to cool a room on the user side, dissipating the condensation heat in air by means of a finned block condenser.

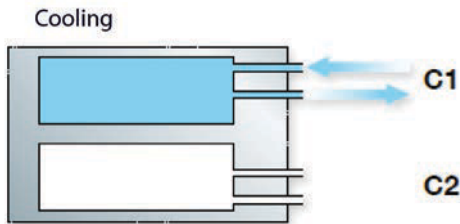

Heating

In the “Heat Pump” mode the LCP M unit heats the water in the condenser to provide heating on the user side, absorbing the evaporative cooling capacity in air by means of a finned block heat exchanger.

In other words, a certain amount of heat is drawn from the thermal source, air, which is delivered to the user after reaching a thermal level such as to satisfy needs.

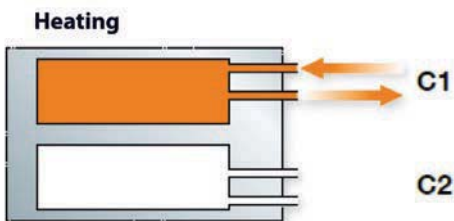

Hot water production (for sanitary use-DHW)

In the “Production of High-temperature Hot Water for sanitary use (DHW)” mode the LCP M multifunctional unit heats water in the second condenser, absorbing the evaporative cooling capacity in air by means of a finned block heat exchanger.

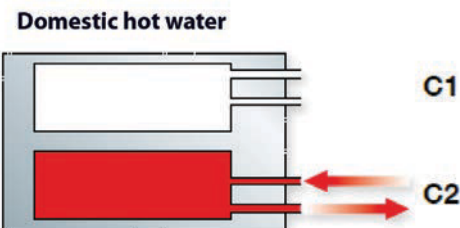

Cooling and hot water production through total recovery

In the “Chiller + DHW” mode the LCP M multifunctional unit can produce chilled water with the simultaneous production of high-temperature hot water for sanitary use, thanks to total heat recovery.



Production of hot water (for example for sanitary use) simultaneously with heating

In the “Simultaneous DHW Production and Heating” mode the LCP M multifunctional unit heats water in parallel, optimally exploiting the complete independence of its thermodynamic circuits. Capacity is equally divided between the two circuits.



LCP units enable the installation of a simple air conditioning system, either 2-pipe or 4-pipe.

The designation “two-pipe” or “four-pipe” refers to the system for distributing the water used by all the air conditioning equipment of a building.

A two-pipe system has a single supply line and a single line for the return of water to the unit. The indoor units served by a two-pipe system contain only an exchanger, which works alternatively as a heating or cooling coil, according to the operating mode.

The four-pipe system has a distribution system that simultaneously offers both hot water (with respective return lines) and chilled water (with respective return lines) (for example, cooling systems with dehumidification + post-heating).

Schematic illustration of a 2-pipe air conditioning system:

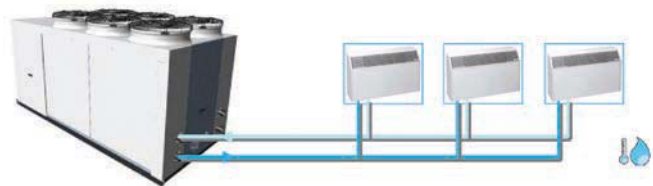

Schematic illustration of a 4-pipe air conditioning system:

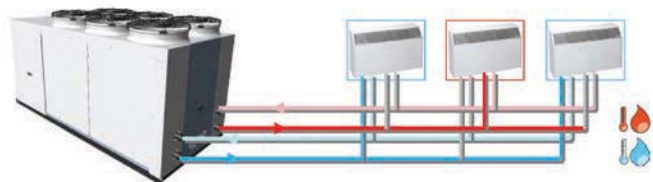

Two-pipe systems are less flexible than a four-pipe system, since the entire building is alternatively in the heating or cooling mode; however, they enable large savings to be achieved when it comes to installing the system.

If design requirements call for a 4-pipe system, LCP P units, compatible with this configuration, are available on request.

POSSIBLE COMBINATIONS OF OPERATING MODES WITH VARIATIONS IN THERMAL LOAD

The possible operating modes of LCP units under partial load conditions are listed in the tables below.

The units are equipped with two thermodynamic circuits and two or four compressors, which combine their operation to satisfy the variable requirements of the air conditioning system.

For example, in the winter mode, LCP units are capable of dividing their power evenly, 50% to domestic hot water and 50% to heating.

Unit with 2 Compressors 2 Cooling circuits:

Summer Mode:	Winter Mode:
<ul style="list-style-type: none"> 100% Cooling 50% Cooling 	<ul style="list-style-type: none"> 100% Heating 50% Heating
<ul style="list-style-type: none"> 100% Cooling + 100% DHW 50% Cooling + 50% DHW 	
<ul style="list-style-type: none"> 50% Cooling + 100% DHW 100% Cooling + 50% DHW 	<ul style="list-style-type: none"> 50% Heating + 50% DHW
<ul style="list-style-type: none"> 100% DHW 50% DHW 	<ul style="list-style-type: none"> 100% DHW 50% DHW

Unit with 4 Compressors 2 Cooling circuits:

Summer Mode:	Winter Mode:
<ul style="list-style-type: none"> 100% Cooling 75% Cooling 50% Cooling 25% Cooling 	<ul style="list-style-type: none"> 100% Heating 75% Heating 50% Heating 25% Heating
<ul style="list-style-type: none"> 100% Cooling + 100% DHW 75% Cooling + 75% DHW 50% Cooling + 50% DHW 25% Cooling + 25% DHW 	
<ul style="list-style-type: none"> 50% Cooling + 100% DHW 25% Cooling + 100% DHW 100% Cooling + 50% DHW 100% Cooling + 25% DHW 	<ul style="list-style-type: none"> 50% Heating + 50% DHW 50% Heating + 25% DHW 25% Heating + 50% DHW 25% Heating + 25% DHW
<ul style="list-style-type: none"> 100% DHW 75% DHW 50% DHW 25% DHW 	<ul style="list-style-type: none"> 100% DHW 75% DHW 50% DHW 25% DHW

SOLUTION TO THE PROBLEM OF DEFROSTING

LCP units provide excellent thermodynamic efficiency and utmost flexibility of use, thanks to constant product research: they can drive a 2- or 4-pipe system, produce DHW simultaneously with chilled water and cover a wide range of capacities.

The combined application of scroll compressors, advanced control systems and the refrigerant gas R410A results in compact circuits and high COPs.

Thanks to the presence of two thermodynamic circuits which are completely independent of each other, the LCP M presents itself on the market as a unique offering, capable of producing hot water for heating while simultaneously carrying out a defrost cycle or guaranteeing the replenishment of domestic hot water.

During the wintertime period, especially with temperatures ranging between 3°C and +3°C, the high ambient relative humidity causes the formation of water condensation around the exchanger fins.

Since the exchanger is at a lower temperature than the outdoor air, the water in contact with it ends up hindering the heat exchange necessary for the system to work correctly.

A defrost cycle is a temporary reversal of the thermodynamic cycle which switches the unit into the summer mode and melts the ice present between fins.

This phase is obviously problematic, since the cooling cycle warms up the exchanger by drawing heat from the room that was previously being heated. The circuit that is defrosting will draw heat on the user side (that is, not on the DHW side) if the unit is LCP M, and will heat on the hot water user side if the unit is LCP P.

The LCP unit reduces this problem with the following technical innovations:

Hydrophilic coils are installed; these break down the drops of water into particles and reduce the obstruction of the space between one fin and another caused by ice build-up.

Thanks to a lower surface tension, the water tends to slide and precipitate by gravity, preventing the formation of frost at low temperatures.



The software which manages the defrost cycle minimizes the time it takes to complete it and only acts when it is really necessary. The fans are pushed to their maximum capacity at just the right time, that is, when the ice is no longer stuck to the fins, and mechanically ejects it from the heat exchanger.

The two thermodynamic circuits in the LCP M and LCP P are completely independent and while one defrosts, the other circuit is able to ensure continuity in the unit's operation, with practically no thermal discomfort for the user.

Separate defrosting



LCP - HS / PS			41	51	61	71	81	94	104	124
Summer Mode	Cooling capacity (1)	kW	51,7	56,4	67,6	74,18	82,82	102,3	111,46	134,64
	Total Input power (1)	kW	15,93	17,9	20,4	22,9	26,64	32,3	36,5	43,42
	EER (1)		3,25	3,14	3,31	3,23	3,11	3,17	3,05	3,1
	Cooling capacity (2)	kW	50,6	56,1	59,3	73,18	83,97	101,9	112,13	131,01
	Heating capacity (2)	kW	65,22	72,2	79,1	93,76	107,15	130,64	144,33	167,86
	Total Input power (2)	kW	16,29	18,12	22	23,41	26,45	32,59	36,23	45,08
	Total COP (2) (**)		7,68	7,57	7,79	7,71	7,83	7,69	7,57	6,2
	Heating capacity (3)	kW	77,81	86	100,44	111,01	124,3	154,24	170,45	199,68
	Total Input power (3)	kW	18,18	20,21	23,43	26,09	28,96	36,33	40,4	49,82
COP (3)		4,28	4,26	4,29	4,25	4,29	4,25	4,22	4,01	
Winter Mode	Heating capacity (4)	kW	56,25	62,05	72,89	80,77	89,38	11,45	123,08	146,96
	Total Input power (4)	kW	15,96	17,83	20,78	23,18	26,07	31,9	35,49	44,53
	COP (4)		3,52	3,48	3,51	3,48	3,46	3,49	3,47	3,3
	Heating capacity (5)	kW	55,63	61,26	71,98	79,64	89,14	110,25	121,39	145,08
	Total Input power (5)	kW	16	19,2	22,33	25,17	28,25	34,39	38,38	47,63
COP (5)		3,23	3,19	3,22	3,16	3,16	3,21	3,16	3,05	
Expansion tanks	dm ³	8	8	8	8	8	12	12	25	
Tank capacity (*)	dm ³	200	200	220	220	220	340	340	600	
Frame		1	1	2	2	2	3+	3+	4	
Height	mm	1720	1720	1720	1720	1720	1720	1720	1830	
Length	mm	2010	2010	2360	2360	2360	3540	3540	3540	
Depth	mm	1185	1185	1185	1185	1185	1185	1185	1654	
Sound pressure @ 10 m Q=2	dB(A)	52	52	53	53	53	54	54	56	
LCP - HS / PS			144	164	194	214	244	274	294	324
Summer Mode	Cooling capacity (1)	kW	147,92	166,53	193,63	220,56	238,6	264,3	298,97	314,03
	Total Input power (1)	kW	48,42	54,84	66,19	74,6	83,14	98,3	101,96	114,5
	EER (1)		3,05	3,04	2,93	2,96	2,87	2,89	2,93	2,73
	Cooling capacity (2)	kW	144,86	165,08	197,74	222,23	245,72	268,79	304,5	326,61
	Heating capacity (2)	kW	186,26	211,79	252,69	286,12	315,58	345,39	390,66	422,71
	Total Input power (2)	kW	49,88	55,46	64,14	73,55	79,83	89,04	99,1	109,56
	Total COP (2) (**)		7,6	7,67	7,79	7,56	7,63	7,62	7,66	7,41
	Heating capacity (3)	kW	218,11	250,03	291,94	339,2	368,62	408,75	459,56	468,18
	Total Input power (3)	kW	54,96	61,17	70,72	81,35	89,05	99,49	110,46	121,47
COP (3)		3,97	4,09	4,13	4,17	4,14	4,11	4,16	3,85	
Winter Mode	Heating capacity (4)	kW	162,66	180,94	211,29	246,24	266,66	294,59	330,97	340,81
	Total Input power (4)	kW	49,53	55,32	63,77	73,25	78,61	87,35	97,41	108,4
	COP (4)		3,28	3,29	3,33	3,38	3,41	3,39	3,41	3,16
	Heating capacity (5)	kW	160,5	178,91	209,77	243,71	264,27	291,45	327,79	337,6
	Total Input power (5)	kW	53,34	59,52	69,09	78,92	84,41	93,82	104,35	115,57
COP (5)		3,01	3,01	3,04	3,09	3,13	3,11	3,14	2,92	
Expansion tanks	dm ³	25	25	25	25	25	25	25	25	
Tank capacity (*)	dm ³	600	600	600	600	600	765	765	765	
Frame		4	4	5	5	5	6	6	6	
Height	mm	1830	1830	2174	2174	2174	2174	2174	2174	
Length	mm	3540	3540	3540	3540	3540	4296	4296	4296	
Depth	mm	1654	1654	1654	1654	1654	1654	1654	1654	
Sound pressure @ 10 m Q=2	dB(A)	56	57	57	58	58	58	59	59	

- (1) Summer mode for production of chilled water alone on exchanger "S1" @ 12/7°C with outdoor air 35°C.
- (2) Summer mode for simultaneous production of chilled water on exchanger "S1" @ 12/7°C and hot water on exchanger "S2" @ 40/45°C.
- (3) Summer mode for production of hot water alone on exchanger "S2" @ 45/50? with outdoor air 35°C.
- (4) Winter mode for production of hot water alone on exchanger "S1" @ 40/45°C with outdoor air 7°C RH90% [possible with unit in version "H"].
- (5) Winter mode for production of hot water alone on exchanger "S2" @ 40/50? with outdoor air 7°C RH90%.

LCP - HL / PL			41	51	61	71	81	94	104	124
Summer Mode	Cooling capacity (1)	kW	49,6	53,84	65,05	70,82	78,62	98,03	105,94	127,62
	Total Input power (1)	kW	16,22	18,54	20,64	23,56	27,73	33,05	37,82	44,39
	EER (1)		3,1	2,9	3,1	3	2,8	2,9	2,7	2,8
	Cooling capacity (2)	kW	50,86	56,1	66,1	73,18	83,97	101,9	112,13	131,01
	Heating capacity (2)	kW	65,22	72,2	84,47	93,76	107,15	130,64	144,33	167,86
	Total Input power (2)	kW	15,66	17,49	20,13	22,47	25,21	31,33	34,98	42,8
	Total COP (2) (**)		7,68	7,57	7,79	7,71	7,83	7,69	7,57	7,71
	Heating capacity (3)	kW	77,12	85,23	99,12	109,24	123,37	152,21	167,41	193,59
	Total Input power (3)	kW	17,54	19,57	22,48	25,04	27,91	35,02	39,11	47,48
COP (3)		4,4	4,36	4,41	4,36	4,42	4,35	4,28	4,08	
Winter Mode	Heating capacity (4)	kW	55,72	61,47	72,22	80,03	88,54	110,4	121,91	141
	Total Input power (4)	kW	15,32	17,19	19,83	22,23	25,14	30,63	34,22	42,16
	COP (4)		3,64	3,58	3,64	3,6	3,52	3,6	3,56	3,34
	Heating capacity (5)	kW	55,13	60,7	70,7	78,32	87,53	108,39	119,32	138,73
	Total Input power (5)	kW	16,57	18,56	21,37	24,13	27,34	32,97	36,94	45,27
COP (5)		3,33	3,27	3,31	3,25	3,2	3,29	3,23	3,06	
Expansion tanks	dm ³	8	8	8	8	8	12	12	25	
Tank capacity (*)	dm ³	200	200	220	220	220	340	340	600	
Frame		1	1	2	2	2	3+	3+	4	
Height	mm	1720	1720	1720	1720	1720	1720	1720	1830	
Length	mm	2010	2010	2360	2360	2360	3540	3540	3540	
Depth	mm	1185	1185	1185	1185	1185	1185	1185	1654	
Sound pressure @ 10 m Q=2	dB(A)	45	46	48	48	48	49	49	51	
LCP - HL / PL			144	164	194	214	244	274	294	324
Summer Mode	Cooling capacity (1)	kW	138,51	153,76	187,63	215,12	232,67	258,62	291,7	304,57
	Total Input power (1)	kW	50,51	58,58	66,59	75,13	84,02	91,7	103,37	117,32
	EER (1)		2,7	2,6	2,7	2,9	2,8	2,7	2,7	2,6
	Cooling capacity (2)	kW	144,86	165,08	197,74	222,23	245,72	288,79	304,5	326,61
	Heating capacity (2)	kW	186,26	211,79	252,69	286,12	215,58	245,39	390,66	422,71
	Total Input power (2)	kW	47,6	53,18	61,86	71,27	77,55	86,74	96,8	107,26
	Total COP (2) (**)		7,6	7,67	7,79	7,56	7,63	7,62	7,66	7,41
	Heating capacity (3)	kW	214,26	245,93	290,62	339,2	368,62	405,16	459,56	468,18
	Total Input power (3)	kW	52,67	58,67	68,44	79,07	86,77	97,12	108,16	119,17
COP (3)		4,07	4,19	4,25	4,29	4,25	4,17	4,25	3,93	
Winter Mode	Heating capacity (4)	kW	155,52	178,39	210,31	245,36	266,66	294,59	330,97	340,81
	Total Input power (4)	kW	47,06	53,08	61,5	70,68	76,33	85,05	95,11	106,1
	COP (4)		3,3	3,36	3,42	3,47	3,49	3,46	3,48	3,21
	Heating capacity (5)	kW	153,7	178,87	207,15	242,62	263,1	290,44	326,32	336,09
	Total Input power (5)	kW	50,88	57,32	66,57	76,65	82,11	91,16	102,03	114,27
COP (5)		3,02	3,12	3,11	3,17	3,2	3,19	3,2	2,94	
Expansion tanks	dm ³	25	25	25	25	25	25	25	25	
Tank capacity (*)	dm ³	600	600	600	600	600	765	765	765	
Frame		4	4	5	5	5	6	6	6	
Height	mm	1830	1830	2174	2174	2174	2174	2174	2174	
Length	mm	3540	3540	3540	3540	3540	4296	4296	4296	
Depth	mm	1654	1654	1654	1654	1654	1654	1654	1654	
Sound pressure @ 10 m Q=2	dB(A)	51	52	53	54	54	55	55	55	

(1) Summer mode for production of chilled water alone on exchanger "S1" @ 12/7°C with outdoor air 35°C.

(2) Summer mode for simultaneous production of chilled water on exchanger "S1" @ 12/7°C and hot water on exchanger "S2" @ 40/45°C.

(3) Summer mode for production of hot water alone on exchanger "S2" @ 40/45°C with outdoor air 35°C.

(4) Winter mode for production of hot water alone on exchanger "S1" @ 40/45°C with outdoor air 7°C RH90% [possible with unit in version "H"].

(5) Winter mode for production of hot water alone on exchanger "S2" @ 40/45°C with outdoor air 7°C RH90%.

TOTAL HEAT RECOVERY MULTI-PURPOSE REVERSIBLE WATER/WATER HEAT PUMPS

- > GEOTHERMAL SYSTEM
- > HEATING
- > AIR CONDITIONING
- > COOLING
- > DEHUMIDIFICATION
- > DOMESTIC HOT WATER
- > MAXIMUM ENERGY EFFICIENCY
- > TOTAL HEAT RECOVERY
- > EXTREMELY QUIET OPERATION

LEP units have been designed for medium-high capacity applications (e.g. multi-residential or commercial units) and cover a range of heating capacities, from 40 to 420 kW, guaranteeing a high thermodynamic efficiency and broad configurability, both in terms of accessories and cooling circuits.

LEP chillers have been designed as fully enclosed units to ensure exceptionally quiet operation, so that they need not be installed in a closed-off area, and they feature an innovative rounded shape which softens their aesthetic impact.

LEP multifunctional units have 6 water connections for three different plumbing circuits for 2-pipe systems:

- Circuit 1, production of chilled or hot water
- Circuit 2, production of hot or cold water for dissipation in opposition to user side
- Circuit 3, hot water production for sanitary use (DHW)

For this reason, multifunction units contain 3 distinct heat exchangers:

- "1" plate heat exchanger with evaporating and condensing function designed for user circuit
- "2" plate heat exchanger with evaporating and condensing function designed for dissipation circuit
- "3" plate heat exchanger designed for the DHW circuit with condensing function

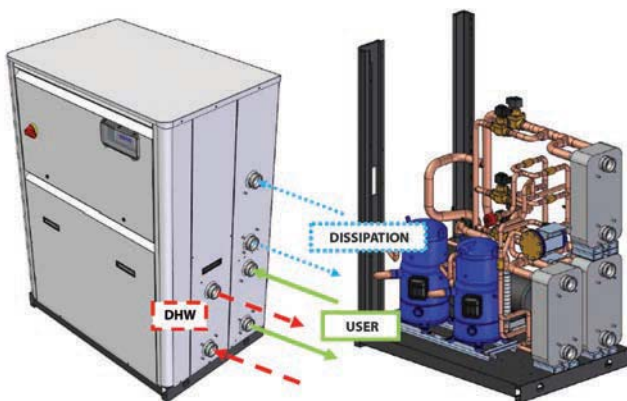

OPERATING MODES OF LEP TOTAL HEAT RECOVERY MULTI-PURPOSE UNITS

In the "Chiller" mode the unit cools water to air condition the interior on the user side, dissipating the condensation heat by means of water that is cooled in the dissipation exchanger.

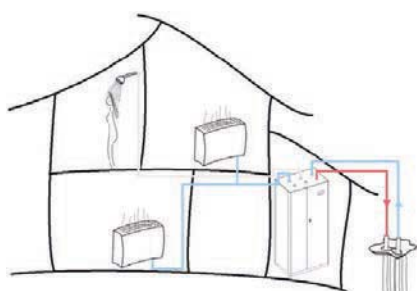

In the "Heat pump" mode the unit heats water in the condenser to provide indoor heating on the user side, dissipating the evaporation cooling capacity by means of water that is heated in the dissipation exchanger.

In other words, a certain amount of heat is drawn from the thermal source, which is delivered to the user after reaching a thermal level such as to satisfy needs.

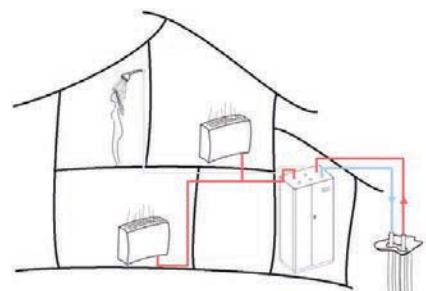

In the "production of high-temperature sanitary hot water (DHW)" mode the unit heats water in the condenser, dedicated to DHW if necessary, dissipating the evaporative cooling capacity by means of water that is heated in the exchanger on the dissipation side.

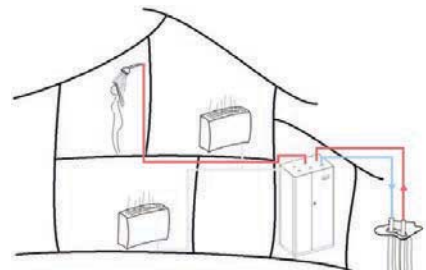

In the "Chiller + DHW" mode the unit can produce chilled water with the simultaneous production of high-temperature hot water for sanitary use, thanks to total heat recovery.

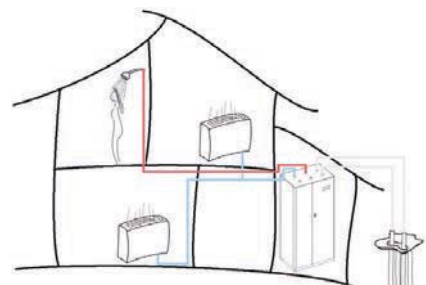

LEP units enable the installation of a simple air conditioning system, either 2-pipe or 4-pipe.

The designation "two-pipe" or "four-pipe" refers to the system for distributing the water used by all the air conditioning equipment of a building.

A two-pipe system has a single supply line and a single line for the return of water to the unit.
The indoor units served by a two-pipe system contain only an exchanger, which works alternatively as a heating and cooling coil, according to the operating mode.
The four-pipe system has a distribution system that simultaneously offers both hot water (with respective return lines) and chilled water (with respective return lines).

Schematic illustration of a 2-pipe air conditioning system:

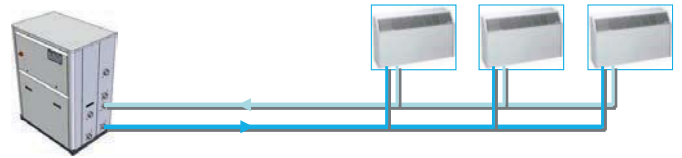

Schematic illustration of a 4-pipe air conditioning system:

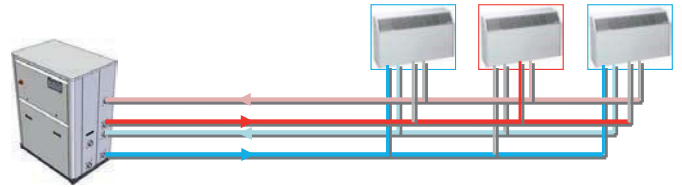

LEP technical data		42	52	62	72	82	92	112	132	142	144	162	164
Cooling mode: user 12 - 7°C, dissipation 15 - 30°C													
Cooling capacity	kW	51,1	60,1	69,7	78,5	90,5	101	122,1	139,2	159,5	159,3	177,8	178,3
Electrical input	kW	8,65	11,2	12,2	14	15,3	17,4	20,2	23,2	27	27,9	31	30,8
Absorbed current	A	13,9	7,9	19,5	22,5	24,6	27,9	32,3	3,2	43,3	44,8	49,6	49,4
EER		5,91	5,38	5,73	5,59	5,9	5,8	6,06	6	5,91	5,71	5,75	5,82
USER Water flow	l/h	8777	10328	11976	13482	15535	17340	20965	23909	27398	27363	30542	30787
USER water pressure drops	kPa	37	49	50	48	38	48	41	50	48	47	52	52
DISSIPATION Water Flow	l/h	3414	4072	4678	5285	6043	6761	8127	9280	10656	10694	11952	11998
DISSIPATION Water pressure drop	kPa	7	9	7	9	7	8	7	9	8	8	9	9
Cooling and total heat recovery (DHW): user side temperature (system) 12 - 7°C, recovery side temperature (DHW) 45 - 50°C													
Cooling capacity	kW	39,9	47,6	54,2	61,8	70,6	78,7	95,2	108,3	124,6	125,5	139,2	139,6
Heating capacity	kW	52,6	63,4	71,7	82,1	93,1	104,3	125,3	143,3	164,4	165,47	184	184,8
Electrical input	kW	13,4	16,6	18,4	21,3	23,7	27	31,7	36,9	41,9	42,3	47,1	47,6
Absorbed current	A	21,5	26,6	29,6	34,2	38	43,3	50,8	59,1	67,2	67,9	75,6	76,3
TOTAL COP		6,9	6,68	6,83	6,75	6,92	6,78	6,96	6,83	6,9	6,88	6,86	6,82
USER Water flow	l/h	6749	8178	9312	10618	12124	13508	16343	18601	21400	21545	23907	23975
USER water pressure drops	kPa	23	32	32	31	24	30	26	32	30	31	34	33
DHW water flow	l/h	9163	11098	12489	14290	16206	18161	21807	24956	28621	28845	32034	32276
DHW pressure drops	kPa	38	54	40	53	40	50	41	53	49	50	54	55
Heating mode: user 40 - 45°C, dissipation 15 - 10°C													
Heating capacity	kW	59	70,9	80,5	91,7	104,4	116,9	140,3	160,3	184,2	185,5	206,3	207
Electrical input	kW	12,1	15,3	16,9	19,5	21,4	24,4	28,5	33,2	37,9	38,7	42,8	43,1
Absorbed current	A	19,5	24,5	27	31,2	34,4	39,1	45,8	53,2	60,7	62	68,7	69,2
COP		4,87	4,64	4,78	4,71	4,87	4,79	4,92	4,83	4,86	4,8	4,82	4,8
USER Water flow	l/h	10253	12322	13994	15941	18139	20315	24385	27855	32009	32243	35854	35982
USER water pressure drops	kPa	47	66	49	64	49	61	50	65	60	61	67	68
DISSIPATION Water Flow	l/h	8164	9694	11093	12594	14447	16114	19466	22145	25486	25589	28482	28558
DISSIPATION Water pressure drop	kPa	32	44	44	43	33	42	36	44	42	42	46	46
Heating mode: DHW 45 / 50°C, dissipation 15 / 10°C													
Heating capacity	kW	57,2	68,8	77,9	89	101,7	113,3	136	155,5	178,4	179,8	199,6	200,6
Electrical input	kW	13,4	16,8	18,6	21,4	23,7	27	31,7	36,9	41,9	42,7	47,2	47,7
Absorbed current	A	21,5	26,9	29,8	34,4	38,1	43,4	50,9	59,2	67,3	68,4	75,7	76,5
COP		4,26	4,1	4,2	4,15	4,25	4,19	4,29	4,21	4,25	4,21	4,23	4,2
USER Water flow	l/h	9954	11974	13568	15495	17586	19729	23683	27080	31061	31298	34754	34927
USER water pressure drops	kPa	45	62	47	61	47	58	48	64	57	58	63	64
DISSIPATION Water Flow	l/h	7638	9090	10370	11801	13492	15072	18212	20714	23817	23942	26613	26700
DISSIPATION Water pressure drop	kPa	29	39	39	38	29	37	32	39	37	37	41	41
Maximum absorbed current	A	30	37	40	46	50	61	70	79	91	92	102	100
Inrush current	A	111	156	157	164	176	203	238	244	289	197	2698	211
Sound power level	dB/A	72	72	73	73	74	76	76	77	77	80	77	80
LEP technical data		182	184	204	214	243	244	283	284	314	344	374	424
Cooling mode: user 12 - 7°C, dissipation 15 - 30°C													
Cooling capacity	[kW]	212,2	206,5	224	244,8	272,7	284	314	317,5	349,5	382,7	415,9	475,7
Electrical input	[kW]	35,9	34,4	37,5	40,3	45,7	45,8	53,8	53,7	61,8	66,9	71,8	78,5
Absorbed current	[A]	57,6	55,2	60,1	64,6	3,4	73,4	86,3	86,2	99,2	107,3	115,2	125,9
EER	[-]	5,91	6	5,98	6,08	5,96	6,21	5,84	5,91	5,66	5,72	5,79	6,06
USER Water flow	[kg/h]	36436	35456	38469	42044	46837	48775	53931	54517	60081	65730	71427	81686
USER water pressure drops	[kPa]	46	45	51	9	51	33	39	40	48	47	46	48
DISSIPATION Water Flow	[kg/h]	14171	13762	14938	16288	18194	13844	21010	21204	23510	25680	27860	31661
DISSIPATION Water pressure drop	[kPa]	8	8	9	9	9	5	7	7	8	8	8	8
Cooling and total heat recovery (DHW): user side temperature (system) 12 - 7°C, recovery side temperature (DHW) 45 - 50°C													
Cooling capacity	[kW]	165,6	161,2	174,6	190,9	215,2	222,9	246,5	249,8	275,5	303,3	326,4	370,2
Heating capacity	[kW]	217,6	211	230,2	251	281,5	391,9	324,7	329,2	365,2	397,5	430,9	492,8
Electrical input	[kW]	54,8	53,4	58,6	63,3	69,8	72,7	82,3	83,6	94,5	102,3	110	129
Absorbed current	[A]	87,8	85,7	93,9	101,5	111,9	116,6	132	134	151,5	164	176,4	206,8
TOTAL COP	[-]	7	6,99	6,91	6,98	7,12	7,08	6,94	6,93	6,78	6,82	6,89	6,69
USER Water flow	[kg/h]	28435	27682	29976	32779	36959	38272	42328	42905	47307	51571	56052	63583
USER water pressure drops	[kPa]	30	29	33	31	33	22	25	26	31	30	30	30
DHW water flow	[kg/h]	37884	36899	40076	43696	49008	50823	56523	57320	63582	69200	75015	85791
DHW pressure drops	[kPa]	48	46	54	52	55	32	40	42	5	49	48	50
Heating mode: user 40 - 45°C, dissipation 15 - 10°C													
Heating capacity	[kW]	244,3	258	281,23	315,1	325,7	363	367,5	407,7	444,8	481,4	547,5	
Electrical input	[kW]	50	48,2	52,9	57	63,3	65,4	75,1	75,6	85,8	93,1	100,3	115
Absorbed current	[A]	80,1	77,4	84,8	91,4	101,6	104,9	120,4	121,2	137,5	149,2	160,9	184,5
COP	[-]	4,89	4,93	4,85	4,94	4,98	4,98	4,84	4,86	4,75	4,78	4,8	4,76
USER Water flow	[kg/h]	42543	41353	44837	48891	54768	56606	63082	63868	70853	77301	83657	95146
USER water pressure drops	[kPa]	59	57	67	63	67	39	48	51	62	60	59	61
DISSIPATION Water Flow	[kg/h]	33846	33038	35730	39066	43844	45326	50157	50846	56099	61287	66384	75351
DISSIPATION Water pressure drop	[kPa]	41	40	45	43	45	29	34	35	42	41	41	41
Heating mode: DHW 45 / 50°C, dissipation 15 / 10°C													
Heating capacity	[kW]	236,1	230,3	249,9	272,4	305,2	316,2	351,5	356,3	395,5	431,7	466,5	532,6
Electrical input	[kW]	55	53,5	58,6	63,4	69,9	72,8	82,7	83,7	94,6	102,5	110,7	129,1
Absorbed current	[A]	88,2	85,8	94	101,6	112,1	116,8	132,6	134,3	151,7	164,4	177,5	207
COP	[-]	4,29	4,31	4,26	4,3	4,36	4,34	4,25	4,25	4,18	4,21	4,22	4,13
USER Water flow	[kg/h]	41110	40089	43500	47428	53130	55050	61202	62033	68860	75155	81221	92726
USER water pressure drops	[kPa]	56	54	63	60	63	37	46	48	59	57	56	58
DISSIPATION Water Flow	[kg/h]	31615	30861	33386	36495	41055	42476	46940	47590	52559	57485	62144	70502
DISSIPATION Water pressure drop	[kPa]	36	35	40	38	40	26	30	31	38	37	36	37
Maximum absorbed current	A	116	122	132	142	153	159	174	182	204	218	232	281
Inrush current	A	361	250	321	328	336	301	401	355	374	437	442	490
Sound power level	dB/A	78	81	81	81	81	82	81	82	82	82	83	83

HIGH TEMPERATURE HEAT PUMPS AS REPLACEMENT

CHARACTERISTICS

REFRIGERANT: R407C

QUIET OPERATION

COMPACT UNITS

- 1190 x 340 x 1235 mm

TOP QUALITY COMPONENTS

INTEGRATED HYDRONIC MODULE

- 3 speed circulation pump
- Air vent valves
- Pressure gauges
- Hydraulic filter

FUNCTIONS OF THE CONTROL SYSTEM

- Reduction in minimum volume of water in the system
- Automatic control of the circulation pump (antifreeze function, anti-seizure function)
- Defrost regulation according to the outdoor temperature
- Management of alarms with recording of events
- External communication via a serial interface (Modbus protocol)

OTHER ADVANTAGES:

- Easy access to components
- Keypad/display on front panel
- Partition between the fan and technical compartment
- Removable control panel to permit a larger opening
- Rigorous control of production: tightness test of the cooling circuit, electric, dielectric test, water circuit test, etc.
- Base antifreeze protection by means of a heating element



STANDARD EQUIPMENT:

- Single-phase start-up kit (MSHTJ 14 single-phase)
- Antifreeze heating element
- Water flow control
- Low pressure switch
- High pressure switch
- Water filter (to be connected)
- Integrated hydronic module

HEATING

OPERATING LIMITS

Outdoor air temperature: -16° C in heating mode
Maximum water outlet temperature: +65° C in heating mode

SCROLL COMPRESSOR WITH INTERMEDIATE INJECTION

TECHNICAL DATA of MSHTJ irreversible heat pumps					
MODEL		MSHTJ 145	MSHTJ 147	MSHTJ 197	
Power supply		230/1/50	400/3/50	400/3/50	
HEATING	Conditions: inlet/outlet water temperature 40/45° C, inlet air temperature 7/6° C (D.B./W.B.); net values; EN 14511-2				
	Rated heating capacity	kW	13,65	13,8	20,4
	Rated input power	kW	5,25	4,98	7,55
	C.O.P	kW/kW	2,60	2,77	2,70
	Nominal water flow rate	m³/h	1,55	1,55	2,3
	Pump available head	kPa	90	90	88
	Conditions: inlet/outlet water temperature */45° C, inlet air temperature -7/-8° C (D.B./W.B.); net values; EN 14511-2				
	Rated heating capacity	kW	8,6	8,6	12,7
	Rated input power	kW	5,04	4,75	7,47
	C.O.P	kW/kW	1,71	1,82	1,7
	Conditions: inlet/outlet water temperature */55° C, inlet air temperature 7/6° C (D.B./W.B.); net values; EN 14511-2				
	Rated heating capacity	kW	13	13,2	20,1
	Rated input power	kW	6,3	5,86	9
	C.O.P	kW/kW	2,06	1,51	2,2
	Conditions: inlet/outlet water temperature 40/45° C, inlet air temperature 7/6° C (D.B./W.B.); gross values; Eurovent				
	Rated heating capacity	kW	8,55	8,5	12,6
	Rated input power	kW	5,96	5,63	9,1
C.O.P	kW/kW	1,43	1,51	1,4	
Conditions: inlet/outlet water temperature 30/35° C, inlet air temperature 7/6° C (D.B./W.B.); net values					
C.O.P	kW/kW	3,41	4,02	3,41	
Type of refrigerant		R407C	R407C	R407C	
Number of cooling circuits	no.	1	1	1	
Nbr of compressors	no.	1	1	1	
Starting current	A	44	42	59	
Expansion tank	l	2	2	2	
Diameter of male water connection		1"	1"	1"	
Sound power level	dBA	71,5	71,5	73,5	
Minimum water content of system	l	45	45	65	
Net dimensions (H/L/D)	mm	1235x1190x340	1235x1190x340	1235x1190x340	
Net weight	kg	141	141	145	

CLEARANCE REQUIREMENTS

A 250 mm for models 145 - 147 - 197

This dimension does not take into account configurations including the installation of a hydraulic filter with two isolation valves positioned straight behind the unit: allow for 0.30 metres.

Minimum clearance above the unit: 0.70 metres

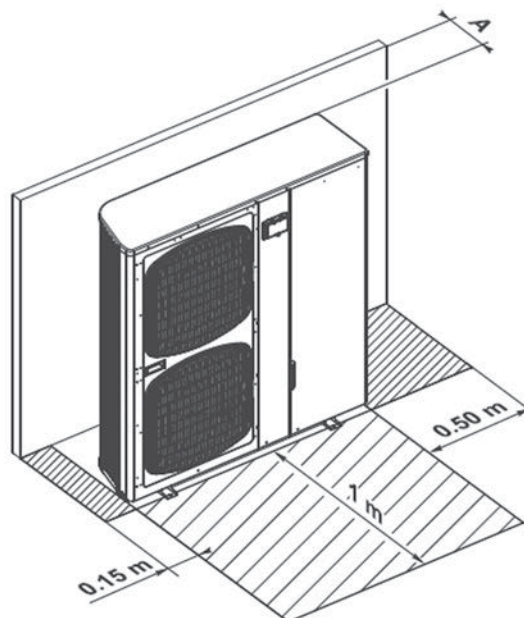

ELECTRIC MODULES

EMC electric modules are designed to back up the operation of Galletti heat pumps when necessary following the inevitable reduction in heating capacity associated with decreases in outdoor air temperature.

They are buffer tanks fitted internally with two armoured electric heating elements, which are activated by the onboard electrical control board according to the control logic described below.

The 2 electric heating elements present inside the buffer tank are controlled by the unit controller.

They are switched on in the heat pump mode when the temperature of the water leaving the condenser falls below the set threshold and the outdoor air temperature is lower than the set threshold values of the two thermostats present on the electrical control board (adjustable thresholds, preset at -5°C and -10°C).

If the outdoor air temperature is below -5°C the first level is activated, if it is below -10°C the second level is activated as well.

The supplemental heating elements also perform an antifreeze function and act as a support in the defrost mode.

In case of alarm (water flow, high pressure, low pressure, etc.) the controller will automatically switch them off.

EMC modules can be installed either externally as a rule in proximity to the heat pump, or inside an equipment enclosure. In the latter case, the air temperature probes must be positioned on the outside of the enclosure housing the module so as to correctly measure the outdoor air temperature (rather than the temperature inside the enclosure).

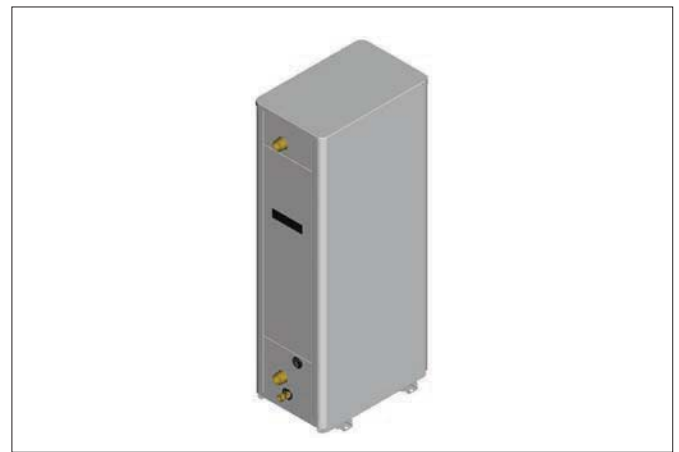

RATED TECHNICAL DATA of EMC tank module with electric heating elements

EMC		EMC22M0000A	EMC22T0000A	EMC24M0000A	EMC24T0000A	EMC33T0000A
Power supply	V/Ph/Hz	230-1-50	400-3N-50	230-1-50	400-3N-50	400-3N-50
No. of reduction steps		2	2	2	2	2
Power input of electric heating element - 1st reduction step	kW	2,0	2,0	2,0	2,0	3,0
Electrical input of heating element - 1st reduction step	A	8,7	2,9	8,7	2,9	4,4
Power input of electric heating element - 2nd reduction step	kW	2,0	2,0	4,0	4,0	3,0
Electrical input of heating element - 2nd reduction step	A	8,7	2,9	17,4	5,8	4,4
Total power input of electric heating elements	kW	4,0	4,0	6,0	6,0	6,0
Total absorbed current of heating elements	A	17,4	5,8	26,1	8,7	8,8
Regulation range of electric heating element thermostat	$^{\circ}\text{C}$	$-10^{\circ}\text{C} / 20^{\circ}\text{C}$	$-10^{\circ}\text{C} / 20^{\circ}\text{C}$	$-10^{\circ}\text{C} / 20^{\circ}\text{C}$	$-10^{\circ}\text{C} / 20^{\circ}\text{C}$	$-10^{\circ}\text{C} / 20^{\circ}\text{C}$
Buffer tank capacity	dm^3	30	30	30	30	50
Height	mm	1.146	1.146	1.146	1.146	1.211
Length	mm	364	364	364	364	364
Depth	mm	466	466	466	466	531
Water connections	inches	1 1/4	1 1/4	1 1/4	1 1/4	1 1/4
Transport weight	kg	45	46	47	48	58
Operating weight	kg	71	72	73	74	104

large systems

LCE

LSE

LEW

LER

LCE: WIDE RANGE OF MODELS AND CONFIGURABILITY

The use of R410A as a refrigerant in specifically developed chillers brings guaranteed advantages thanks to the high exchange coefficients and lower pressure drops in the heat exchanger, which mean enhanced efficiency and reliability plus energy savings.

The LCE project has enabled a range to be developed which, starting off from 18 basic sizes, generates no fewer than 150 different cooling-only or heat pump models - given all the configurations and options that multiply the possibilities of choice - with powers from 40 to approximately 360 kW. A vast array of options and accessories allows you to build "dedicated" solutions tailored to numerous design and installation requirements.

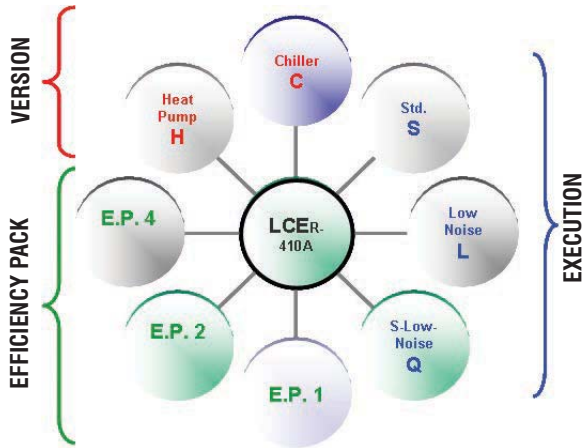

> **VERSION**

- C** Chiller cooling only
- H** reversible heat pump
- F** Free cooling, choices and prices on request

> **EFFICIENCY PACK**

The possibility of setting up different cooling circuits in units of the same power means being able to personalise efficiency levels under full or partial load conditions.

- 1** Dual circuit / dual compressor
The dual circuit-dual compressor models provide high efficiency values under full load (EER and COP).
- 2** Single circuit / dual compressor.
The solution of using two compressors in a single cooling circuit increases efficiency under partial load conditions, reaching ESEER values greater than 4.
- 4** Dual circuit / 4 compressors.
4 compressors enable the unit to output power in 4 steps and adapt perfectly to the actual thermal load of the system, while reducing starting currents.

> **EXECUTION**

- S** Standard execution
- L** Low-Noise execution for a low noise impact
- Q** Quiet execution for a super low noise impact



ELECTRONIC EXPANSION VALVES

All units, irrespective of type of construction, are equipped with electronic expansion valves to maximise efficiency under partial load conditions.

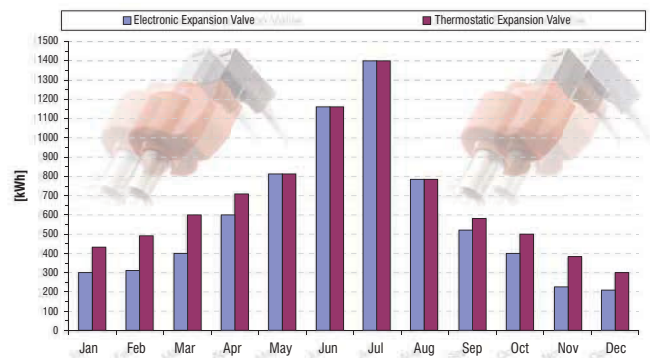

Electronic expansion valves have the capacity, if correctly parameterised and controlled by the software, to optimise cooling circuit performance and decrease the system's power consumption.

When a sudden change occurs in the thermal load, with a traditional expansion valve there is a transient time of 2 to 3 minutes before a condition of equilibrium is reached.

Proactive action of an Electronic Expansion Valve

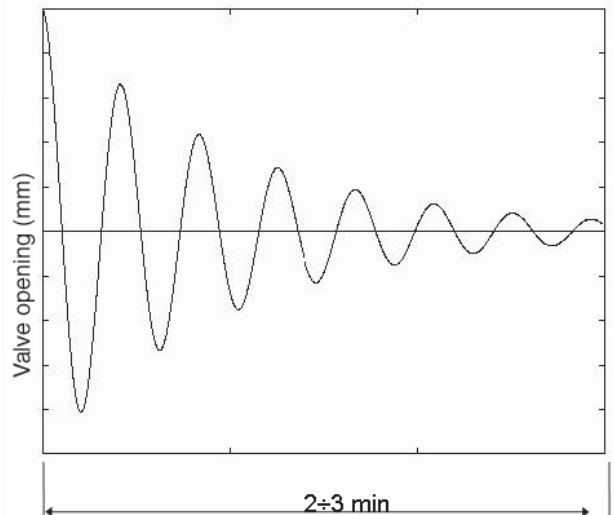

In the event of a compressor on/off request:

- The electronic driver pre-positions the valve at a point very near the final equilibrium point.
- A status of equilibrium is quickly reached with small adjustments.
- The electronic expansion valve becomes an active, rather than passive, component within the system.
- The transient time is greatly reduced.
- Overall the system is more efficient, with higher EERs and therefore greater savings.

WATER PUMP OPTIONS

Complete hydronic kits can be incorporated within the units without modifying their size and you have the option of choosing the water circulation pump.

- Single pump, standard head or uprated.
- Dual pumps, OR solution: standard head or uprated, operating singly. The pumps operate in turns on a time/fault basis. In the case, the microprocessor controls the pumps in such a way as to equally divide the hours of operation, changing over the pumps in the event of a fault.
- Dual pump, "AND" solution: standard or uprated pump, operating simultaneously. Connected in parallel, they deliver water at the nominal flow rate when operating simultaneously.

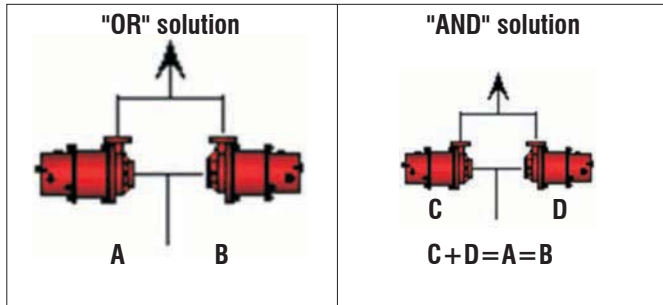

Under partial load conditions operation is limited to a single pump, reducing the capacity by 1/3 compared to the rated value and resulting in average savings of about 30% in pumping costs.

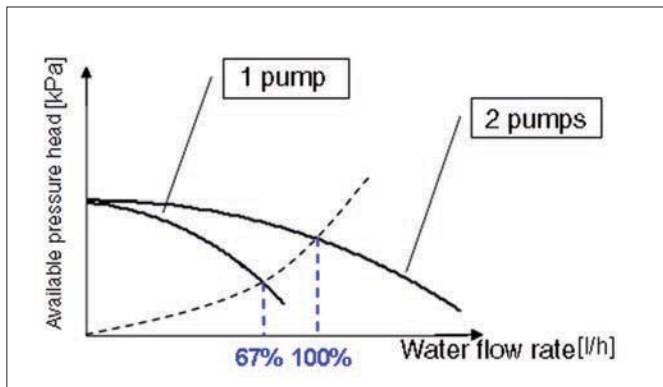

In the case of two pumps in combination, the advanced microprocessor is mandatory because it controls the on/off switching of the second pump according to the number of capacity steps required at every instant. This makes operation of the unit cost-effective for most of its life since, based on well-known analyses, chillers operate 97% of the time under partial load conditions.

All LCE models are constructed so that the water inlet and outlet pipes are outside the unit. Pairs of quick connect couplings with a welding ring are available as an optional.



REGULATION

The electronic control system allows the setpoint to be adjusted automatically according to the outdoor temperature (sensor available as an optional) in order to reduce consumption and broaden the working temperature range.

In the summer mode, compensation begins with an outdoor air temperature of 30°C.

The diagram below indicates the increases in efficiency at different water temperatures.

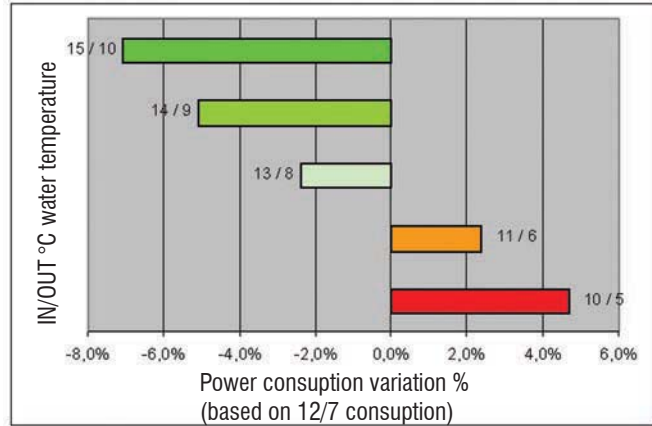

The exclusive defrost system (optional feature available with the advanced controller) can correctly identify an impairment of performance in the outdoor exchanger due to the formation of ice and minimise the process time in relation to normal operation of the unit.

INTERCONNECTIVITY

ERGO networks as a standard feature

With advanced microprocessor control it is possible to implement:

- LAN networks
- GSM kit for reading and setting data via a mobile phone
- WEB kit for reading and setting data remotely from a PC via access to the IP address of the chiller unit or network of units.

REDUCTION IN OVERALL DIMENSIONS/TRANSPORT COSTS

Reduction in footprint and increase in power density (kW/m²). Thanks to the decrease in depth (now 1180 mm up to model 160), it is possible to reduce transport costs.



Rated technical data of LCE water chillers, STANDARD version															
Approx. capacity (kW)		45	50	60	70	80	90			100			120		
Efficiency Pack		2	2	2	2	2	1	2	4	1	2	4	1	2	4
LCE,,,CS		042	052	062	072	082	091	092	094	101	102	104	121	122	124
Power supply	V-ph-Hz	400-3-50													
Cooling capacity	kW	-	-	63,3	69,2	76,5	92,2	-	-	102,8	103,5	-	124,1	123,6	126,4
Total power input	kW	-	-	24,8	27,7	31,7	33,1	36,2	-	39,5	43,3	-	43,1	46,9	42,9
Rated current input	A	-	-	37,83	46,89	53,33	56,88	61,81	-	67,09	66,7	-	74,13	71,46	73,92
EER		-	-	2,56	2,5	2,42	2,78	2,55	-	2,6	2,39	-	2,88	2,64	2,94
ESEER		-	-	3,89	3,93	3,78	3,45	3,88	-	3,4	3,75	-	3,88	4,09	4,09
Maximum current input	A	-	-	60	64	75	91	91	-	101	101	-	119	119	120
Starting current	A	-	-	195	192	200	261	261	-	269	269	-	319	319	247
No. of scroll compressors / circuits		-	-	2 / 1	2 / 1	2 / 1	2 / 2	2 / 1	-	2 / 2	2 / 1	-	2 / 2	2 / 1	4 / 2
No. of axial fans		-	-	4	4	4	6	6	-	6	6	-	8	8	8
Air flow rate	m³/h	-	-	21379	21379	21379	30913	30913	-	30913	30913	-	41340	41340	41340
Water flow rate	l/h	-	-	10887	11902	13158	15858	15858	-	17665	17665	-	21346	21346	21747
Pressure drop, water side	kPa	-	-	46	34	42	31	31	-	38	38	-	39	41,6	40
Available head, standard pump	kPa	-	-	126	133	119	130	130	-	119	119	-	108	108	106
Buffer tank	dm³	-	-	200	200	200	220	220	-	220	220	-	340	340	340
Expansion tank	dm³	-	-	12	12	12	12	12	-	12	12	-	12	12	12
Plumbing connections	"	-	-	2	2	2	2	2	-	2	2	-	2 1/2	2 1/2	2 1/2
Height	mm	-	-	1735	1735	1735	1735	1735	-	1735	1735	-	1735	1735	1679
Length	mm	-	-	2090	2090	2090	2442	2442	-	2442	2442	-	3190	3190	3540
Depth	mm	-	-	1183	1183	1183	1183	1183	-	1183	1183	-	1183	1183	1183
Sound power level	dB(A)	-	-	84,0	84,0	84,0	82,0	86,0	-	82,0	86,0	-	82,0	86,0	82,0
Sound pressure level	dB(A)	-	-	56,0	56,0	56,0	54,0	58,0	-	54,0	58,0	-	54,0	58,0	54,0
Base unit operating weight	kg	-	-	540	570	650	730	730	-	730	730	-	1010	1010	1050
Unit with pump and full tank operating weight	kg	-	-	877	907	987	1138	1138	-	1138	1138	-	1581	1581	1641

Rated technical data of LCE water chillers, STANDARD version															
Approx. capacity (kW)		140			160			170	190	210	240	270	290	320	360
Efficiency Pack		1	2	4	1	2	4	4	4	4	4	4	4	4	4
LCE,,,CS		141	142	144	161	162	164	174	194	214	244	274	294	324	364
Power supply	V-ph-Hz	#RIF!													
Cooling capacity	kW	138,3	137,7	140,3	155,1	154,7	153,4	161,8	186,9	209	237	271,9	296,2	214,3	353,4
Total power input	kW	48,3	52,6	47,7	58,7	64	56,1	61,9	77,3	91,1	101,6	11,9	126,8	131,8	138,1
Rated current input	A	82,46	89,4	81,61	99,17	107,72	94,99	104,45	128,83	150,97	167,841	189,2	205,14	217,98	227,93
EER		2,87	2,62	2,94	2,64	2,42	2,74	2,61	2,42	2,29	2,3	2,39	2,39	2,38	2,56
ESEER		3,93	4,01	4,1	3,61	3,79	3,75	4,04	3,84	3,84	3,89	3,94	3,91	4,05	4,18
Maximum current input	A	131	131	129	137	144	150	136	155	173	196	224	237	251	300
Starting current	A	330	330	245	389	396	266	252	310	330	380	403	468	476	497
No. of scroll compressors / circuits		2 / 2	2 / 1	4 / 2	2 / 2	2 / 1	4 / 2	4 / 2	4 / 2	4 / 2	4 / 2	4 / 2	4 / 2	4 / 2	4 / 2
No. of axial fans		8	8	8	8	8	8	6	6	6	6	8	8	8	8
Air flow rate	m³/h	39890	39890	39890	39890	39890	39890	67672	67672	67672	75478	103511	97902	97902	97902
Water flow rate	l/h	23805	23805	24143	26660	26660	26378	27864	32095	35948	40747	46716	50827	53990	60257
Pressure drop, water side	kPa	48	49	50	42	42	42	46	49	50	53	41	49	55	41
Available head, standard pump	kPa	150	150	147	147	147	148	155	133	147	171	170	152	137	134
Buffer tank	dm³	340	340	340	340	340	340	600	600	600	600	600	600	600	600
Expansion tank	dm³	12	12	12	12	12	12	24	24	24	24	24	24	24	24
Plumbing connections	"	2 1/2	2 1/2	2 1/2	2 1/2	2 1/2	2 1/2	3	3	3	4	4	4	4	4
Height	mm	1735	1735	1679	1735	1735	1679	1847	1847	1847	2247	2330	2330	2330	2330
Length	mm	3190	3190	3540	3190	3190	3540	3538	3538	3538	3538	4206	4206	4206	4206
Depth	mm	1183	1183	1183	1183	1183	1183	1653	1653	1653	1653	1653	1653	1653	1653
Sound power level	dB(A)	82,0	86,0	82,0	82,0	86,0	82,0	87,0	87,0	87,0	87,0	88,0	88,0	88,0	84,0
Sound pressure level	dB(A)	54,0	58,0	54,0	54,0	58,0	54,0	59,0	59,0	59,0	59,0	60,0	60,0	60,0	56,0
Base unit operating weight	kg	1055	1055	1070	1085	1085	1220	1440	1460	1470	1620	1880	1912	1947	1947
Unit with pump and full tank operating weight	kg	1626	1626	1661	1656	1656	1811	2208	2276	2286	2469	2894	2926	2961	2961

Cooling capacity refers to the following conditions: water temperature 12-7°C; outdoor air temperature 35°C
 Sound pressure level refers to the following conditions: measured in an open field, at a distance of 10 m, with a directivity factor of 2.

Rated technical data of LCE water chillers, LOW NOISE version															
Approx. capacity (kW)		45	50	60	70	80	90			100			120		
Efficiency Pack		2	2	2	2	2	1	2	4	1	2	4	1	2	4
LCE...CL		042	052	062	072	082	091	092	094	101	102	104	121	122	124
Power supply	V-ph-Hz	400-3-50													
Cooling capacity	kW	48	52,2	63,6	69,3	76,5	92,8	92,2	94,4	103,5	103,5	101,8	125	123,6	127,5
Total power input	kW	16,2	20,2	24,8	27,7	31,7	32	36,2	32,3	38,4	43,3	37,56	44,5	47,1	44,2
Rated current input	A	27,68	34,16	42,24	46,89	53,34	54,74	61,4	55,25	64,92	72,88	70,2	72,65	76,82	72,25
EER		2,96	2,58	2,56	2,5	2,42	2,9	2,6	2,92	2,7	2,39	2,71	2,81	2,62	2,88
ESEER		4,06	3,96	3,89	3,93	3,78	3,45	3,9	3,9	3,4	3,75	3,85	3,88	4,09	4,09
Maximum current input	A	41	44	51	55	66	77	77,0	81	86	86	87	95	95	96
Starting current	A	159	162	185	183	191	246	246	194	254	254	198	295	295	220
No. of scroll compressors / circuits		2 / 1	2 / 1	2 / 1	2 / 1	2 / 1	2 / 2	2 / 1	4 / 2	2 / 2	2 / 1	4 / 2	2 / 2	2 / 1	4 / 2
No. of axial fans		4	4	6	6	6	8	8	8	8	8	8	6	6	6
Air flow rate	m ³ /h	15398	15398	21955	21955	21955	29393	29393	29393	29393	29393	29393	43434	43434	43434
Water flow rate	l/h	8261	8983	10956	12027	13313	15986	15986,0	16213	17778	17778	17582	21518	21518	21906
Pressure drop, water side	kPa	26	31	47	35	43	31	32,0	32	39	39	38	40	40	41
Available head, standard pump	kPa	157	149	125	131	117	129	129,0	128	118	118	119	107	107	105
Buffer tank	dm ³	200	200	220	220	220	340	340	340	340	340	340	600	600	600
Expansion tank	dm ³	12	12	12	12	12	12	12	12	12	12	12	24	24	24
Plumbing connections	"	2	2	2	2	2	2 1/2	2 1/2	2 1/2	2 1/2	2 1/2	2 1/2	3	3	3
Height	mm	1735	1735	1735	1735	1735	1735	1735	1679	1735	1735	1679	1847	1847	1847
Length	mm	2090	2090	2442	2442	2442	3190	3190	3540	3190	3190	3540	3538	3538	3538
Depth	mm	1183	1183	1183	1183	1183	1183	1183	1183	1183	1183	1183	1653	1653	1653
Sound power level	dB(A)	70,0	74,0	76,0	76,0	76,0	73,0	77,0	73,0	73,0	77,0	73,0	77,0	81,0	77,0
Sound pressure level	dB(A)	42,0	46,0	48,0	48,0	48,0	45,0	49,0	45,0	45,0	49,0	49,0	49,0	53,0	49,0
Base unit operating weight	kg	525	525	630	635	700	905	905	980	915	915	980	1260	1260	1275
Unit with pump and full tank operating weight	kg	862	862	982	987	1067	1426	1426	1557	1436	1436	1557	2040	2040	2055

Rated technical data of LCE water chillers, LOW NOISE version															
Approx. capacity (kW)		140			160			170	190	210	240	270	290	320	360
Efficiency Pack		1	2	4	1	2	4	4	4	4	4	4	4	4	4
LCE...CL		141	142	144	161	162	164	ND	194	214	244	274	294	324	364
Power supply	V-ph-Hz	400-3-50													
Cooling capacity	kW	137,4	137,7	139,7	155,4	154,7	153,7	-	186,9	208,9	237	271,9	296,1	214,3	341,1
Total power input	kW	50,3	52,6	49,6	60,2	64	57,7	-	77,3	91,1	101,6	113,9	123,9	131,9	143,6
Rated current input	A	81,98	85,67	80,89	97,85	96,2	93,85	-	125,26	147,47	156,55	172,95	199,25	212,09	230,88
EER		2,73	2,62	2,82	2,58	2,42	2,66	-	2,42	2,29	2,33	2,39	2,39	2,38	2,37
ESEER		3,93	4,01	4,1	3,61	3,79	3,75	-	3,84	3,84	3,89	3,94	3,91	4,05	4,18
Maximum current input	A	106	106	105	120	120	126	-	148	167	190	215	229	242	300
Starting current	A	306	306	222	371	371	241	-	307	318	382	398	494	472	497
No. of scroll compressors / circuits		2 / 2	2 / 1	4 / 2	2 / 2	2 / 1	4 / 2	-	4 / 2	4 / 2	4 / 2	4 / 2	4 / 2	4 / 2	4 / 2
No. of axial fans		6	6	6	6	6	6	-	6	6	6	8	8	8	8
Air flow rate	m ³ /h	43434	43434	43434	40235	40235	40235	-	55808	63261	63261	87186	81687	81687	81687
Water flow rate	l/h	23655	23655	24043	26719	26719	26434	-	31172	36451	36615	45628	49438	52350	58337
Pressure drop, water side	kPa	48	48	50	43	43	42	-	47	51	50	39	46	52	38
Available head, standard pump	kPa	151	151	148	147	147	148	-	139	143	177	174	158	145	142
Buffer tank	dm ³	600	600	600	600	600	600	-	600	600	600	600	600	600	600
Expansion tank	dm ³	24	24	24	24	24	24	-	24	24	24	24	24	24	24
Plumbing connections	"	3	3	3	3	3	3	-	3	4	4	4	4	4	4
Height	mm	1847	1847	1847	1847	1847	1847	-	1847	2247	2247	2330	2330	2330	2330
Length	mm	3538	3538	3538	3538	3538	3538	-	3538	3538	3538	4206	4206	4206	4206
Depth	mm	1653	1653	1653	1653	1653	1653	-	1653	1653	1653	1653	1653	1653	1653
Sound power level	dB(A)	77,0	81,0	77,0	77,0	81,0	77,0	-	81,0	81,0	82,0	83,0	83,0	83,0	79,0
Sound pressure level	dB(A)	49,0	53,0	49,0	49,0	53,0	49,0	-	53,0	53,0	54,0	55,0	55,0	55,0	51,0
Base unit operating weight	kg	1310	1310	1290	1330	1330	1440	-	1460	1510	1620	1880	1912	1947	1947
Unit with pump and full tank operating weight	kg	2090	2090	2070	2110	2110	2220	-	2276	2326	2469	2894	2926	2961	2961

Cooling capacity refers to the following conditions: water temperature 12-7°C; outdoor air temperature 35°C
 Sound pressure level refers to the following conditions: measured in an open field, at a distance of 10 m, with a directivity factor of 2.

Rated technical data of LCE water chillers, QUIET (super low noise) version															
Approx. capacity (kW)		45	50	60	70	80	90			100			120		
Efficiency Pack		2	2	2	2	2	1	2	4	1	2	4	1	2	4
LCE,,,CQ		042	052	062	072	082	091	092	094	101	102	104	121	122	124
Power supply	V-ph-Hz	400-3-50													
Cooling capacity	kW	48	52,2	63,3	69,3	76,5	92,8	92,2	94,4	103,5	103,5	102,3	123,6	123,6	125,7
Total power input	kW	16,2	20,8	24,8	27,7	31,7	32	36,2	32,3	38,4	43,3	37,1	45,4	47,1	45,1
Rated current input	A	27,68	35,11	42,24	46,89	53,34	54,74	61,4	55,25	64,92	72,88	62,84	73,45	76,84	76,59
EER		2,96	2,51	2,56	2,5	2,42	2,9	2,6	2,92	2,7	2,39	2,76	2,75	2,62	2,79
ESEER		4,06	3,96	3,89	3,93	3,78	3,45	3,9	3,9	3,4	3,75	3,85	3,88	4,09	4,09
Maximum current input	A	41	44	51	55	66	77	77,0	81	86	86	87	95	95	96
Starting current	A	159	162	185	183	191	246	246,0	194	254	254	198	295	295	220
No. of scroll compressors / circuits		2 / 1	2 / 1	2 / 1	2 / 1	2 / 1	2 / 2	2 / 1	4 / 2	2 / 2	2 / 1	4 / 2	2 / 2	2 / 1	4 / 2
No. of axial fans		4	4	6	6	6	8	8	8	8	8	8	6	6	6
Air flow rate	m ³ /h	15.398	15.398	21.955	21.955	21.955	29.393	29.393	29.393	29.393	29.393	29.393	35.930	35.930	35.930
Water flow rate	l/h	8.261	8.983	10.956	12.027	13.313	15.986	15.986	16.213	17.778	17.778	17.582	21.259	21.259	21.623
Pressure drop, water side	kPa	26	44,12	47	35	43	31	32,0	32	39	39	38	39	39	40
Available head, standard pump	kPa	157	149	125	131	117	129	129	128	118	118	119	109	109	106
Buffer tank	dm ³	200	200	220	220	220	340	340	340	340	340	340	600	600	600
Expansion tank	dm ³	12	12	12	12	12	12	12	12	12	12	12	24	24	24
Plumbing connections	"	2	2	2	2	2	2 1/2	2 1/2	2 1/2	2 1/2	2 1/2	2 1/2	3	3	3
Height	mm	1735	1735	1735	1735	1735	1735	1735	1679	1735	1735	1679	1847	1847	1847
Length	mm	2090	2090	2442	2442	2442	3190	3190	3540	3190	3190	3540	3538	3538	3538
Depth	mm	1183	1183	1183	1183	1183	1183	1183	1183	1183	1183	1183	1653	1653	1653
Sound power level	dB(A)	67,0	72,0	73,0	73,0	73,0	70,0	74,0	70,0	70,0	74,0	70,0	69,0	73,0	69,0
Sound pressure level	dB(A)	39,0	44,0	45,0	45,0	45,0	42,0	46,0	42,0	42,0	46,0	42,0	41,0	45,0	41,0
Base unit operating weight	kg	525	525	630	635	700	905	905	980	915	915	980	1260	1260	1275
Unit with pump and full tank operating weight	kg	862	862	982	987	1067	1426	1426	1557	1436	1436	1557	2040	2040	2055

Rated technical data of LCE water chillers, QUIET (super low noise) version														
Approx. capacity (kW)		140			160			170	190	210	240	270	290	320
Efficiency Pack		1	2	4	1	2	4	4	4	4	4	4	4	4
LCE,,,CQ		141	142	144	161	162	164	-	194	214	244	274	294	324
Power supply	V-ph-Hz	400-3-50												
Cooling capacity	kW	135,5	137,7	137,7	151,5	154,7	150,2	-	186,7	208,8	236,9	272	296,1	214,2
Total power input	kW	51,2	52,6	50,8	61,9	64	59,4	-	100,9	91,2	101,7	113,9	123,9	132
Rated current input	A	83,35	85,68	82,76	100,58	103,98	96,53	-	163,1	147,61	164,37	183,42	199,56	212,47
EER		2,65	2,62	2,71	2,45	2,42	2,53	-	1,85	2,29	2,33	2,39	2,39	2,38
ESEER		3,93	4,01	4,1	3,61	3,79	3,75	-	3,84	3,84	3,89	3,94	3,91	4,05
Maximum current input	A	106	106	105	120	120	126	-	148	167	190	215	229	242
Starting current	A	306	306	222	317	317	241	-	307	318	382	398	494	472
No. of scroll compressors / circuits		2 / 2	2 / 1	4 / 2	2 / 2	2 / 1	4 / 2	-	4 / 2	4 / 2	4 / 2	4 / 2	4 / 2	4 / 2
No. of axial fans		6	6	6	6	6	6	-	6	6	6	8	8	8
Air flow rate	m ³ /h	35.930	35.930	35.930	35.930	35.930	35.930	-	35.930	40.953	40.953	69.835	69.835	69.835
Water flow rate	l/h	23.303	23.303	23.667	26.051	26.051	25.816	-	28.282	33.135	36.054	44.837	47.938	50.535
Pressure drop, water side	kPa	47	47	48	40	41	40	-	39	39	42	38	44	48
Available head, standard pump	kPa	153	153	151	151	151	152	-	161	171	193	177	164	153
Buffer tank	dm ³	600	600	600	600	600	600	-	600	600	600	600	600	600
Expansion tank	dm ³	24	24	24	24	24	24	-	24	24	24	24	24	24
Plumbing connections		3	3	3	3	3	3	-	3	4	4	4	4	4
Height	mm	1847	1847	1847	1847	1847	1847	-	1847	2247	2247	2330	2330	2330
Length	mm	3538	3538	3538	3538	3538	3538	-	3538	3538	3538	4206	4206	4206
Depth	mm	1653	1653	1653	1653	1653	1653	-	1653	1653	1653	1653	1653	1653
Sound power level	dB(A)	69,0	73,0	69,0	69,0	73,0	69,0	-	73,0	73,0	73,0	74,0	74,0	74,0
Sound pressure level	dB(A)	41,0	45,0	41,0	41,0	45,0	41,0	-	45,0	45,0	45,0	46,0	46,0	46,0
Base unit operating weight	kg	1310	1310	1290	1330	1330	1440	-	1460	1510	1620	1880	1912	1947
Unit with pump and full tank operating weight	kg	2090	2090	2070	2110	2110	2220	-	2276	2326	2469	2894	2926	2961

Cooling capacity refers to the following conditions: water temperature 12-7°C; outdoor air temperature 35°C
 Sound pressure level refers to the following conditions: measured in an open field, at a distance of 10 m, with a directivity factor of 2.

Rated technical data of LCE heat pumps, STANDARD version															
Approx. capacity (kW)		45	50	60	70	80	90			100			120		
Efficiency Pack		2	2	2	2	2	1	2	4	1	2	4	1	2	4
LCE...HS		042	052	062	072	082	091	092	094	101	102	104	121	122	124
Power supply	V-ph-Hz	400-3-50													
Cooling capacity	kW	-	-	63,3	69,2	76,5	92,3	-	-	102,8	103,5	-	124,1	123,6	126,4
Total power input in cooling mode	kW	-	-	24,8	27,7	31,7	33,1	36,2	-	39,5	43,3	-	43,1	47,1	42,9
Rated current input	A	-	-	42,23	46,89	53,33	56,95	61,81	-	67,09	73,3	-	74,13	80,59	73,92
EER		-	-	2,56	2,5	2,42	2,78	2,55	-	2,6	2,39	-	2,88	2,62	2,94
ESEER		-	-	3,89	3,93	3,78	3,45	3,88	-	3,4	3,75	-	3,88	4,09	4,09
Heating capacity	kW	-	-	70,2	77,6	85,2	101,2	102,5	-	117,2	118,3	-	137,8	138,3	135
Total power input in heating mode	kW	-	-	18,7	21,5	24,6	32,5	28,8	-	37,5	33,6	-	42,7	37,7	42,2
Rated current input	A	-	-	35,53	37,05	41,96	55,97	50,06	-	63,93	57,72	-	73,53	65,48	72,81
COP		-	-	3,75	3,6	3,46	3,11	3,55	-	3,13	3,52	-	3,23	3,67	3,2
Maximum current input	A	-	-	60	64	75	91	91	-	101	101	-	119	119	120
Starting current	A	-	-	195	192	200	261	261	-	269	269	-	319	319	247
No. of scroll compressors / circuits		-	-	2 / 1	2 / 1	2 / 1	2 / 2	2 / 1	-	2 / 2	2 / 1	-	2 / 2	2 / 1	4 / 2
No. of axial fans		-	-	4	4	4	6	6	-	6	6	-	8	8	8
Air flow rate	m ³ /h	-	-	21379	21379	21379	30913	30913	-	30913	30913	-	41340	41340	41340
Water flow rate (cooling)	l/h	-	-	10887	11902	13158	15858	15858	-	17665	17665	-	21346	21346	21747
Pressure drop, water side (cooling)	kPa	-	-	46	34	42	31	31	-	38	38	-	39	39	40
Available head, standard pump (cooling)	kPa	-	-	126	133	119	130	130	-	119	119	-	108	108	106
Buffer tank	dm ³	-	-	200	200	200	220	220	-	220	220	-	340	340	340
Expansion tank	dm ³	-	-	12	12	12	12	12	-	12	12	-	12	12	12
Plumbing connections	"	-	-	2	2	2	2	2	-	2	2	-	2 1/2	2 1/2	2 1/2
Height	mm	-	-	1735	1735	1735	1735	1735	-	1735	1735	-	1735	1735	1679
Length	mm	-	-	2090	2090	2090	2442	2442	-	2442	2442	-	3190	3190	3540
Depth	mm	-	-	1183	1183	1183	1183	1183	-	1183	1183	-	1183	1183	1183
Sound power level	dB(A)			84,0	84,0	84,0	82,0	86,0		82,0	86,0	-	82,0	86,0	82,0
Sound pressure level	dB(A)			56,0	56,0	56,0	54,0	58,0		54,0	58,0	-	54,0	58,0	54,0
Base unit operating weight	kg	-	-	540	570	650	730	730	-	730	730	-	1010	1010	1050
Unit with pump and full tank operating weight	kg	-	-	877	907	987	1138	1138	-	1138	1138	-	1581	1581	1641
Rated technical data of LCE heat pumps, STANDARD version															
Approx. capacity (kW)		140			160			170	190	210	240	270	290	320	360
Efficiency Pack		1	2	4	1	2	4	4	4	4	4	4	4	4	4
LCE...HS		141	142	144	161	162	164	174	194	214	244	274	294	324	364
Power supply	V-ph-Hz	400-3-50													
Cooling capacity	kW	138,3	137,7	140,3	155,1	154,7	153,4	161,8	186,9	209,0	237,0	271,9	296,2	214,3	353,4
Total power input in cooling mode	kW	48,3	52,6	47,7	58,7	64,0	56,1	61,9	77,3	91,1	101,6	113,9	123,8	131,8	138,1
Rated current input	A	82,5	89,4	81,6	99,2	107,7	95,0	104,2	128,8	151,0	167,8	189,2	205,1	218,0	227,9
EER		2,87	2,62	2,94	2,64	2,42	2,74	2,61	2,42	2,29	2,33	2,39	2,39	2,38	2,56
ESEER		3,93	4,01	4,1	3,61	3,79	3,75	4,04	3,84	3,84	3,89	3,94	3,91	4,05	4,18
Heating capacity	kW	152,4	153,1	149,3	179,8	180	175,7	188	211,9	235,8	273,5	306,7	330,5	351,2	425,8
Total power input in heating mode	kW	46,3	41,2	45,8	55,6	50	55	50,4	59,7	67,9	80,1	88,5	97	105,2	124,3
Rated current input	A	79,27	71,12	78,44	94,19	85,29	93,2	85,69	135,3	113,78	133,39	148,48	162,05	175,18	205,88
COP		3,29	3,72	3,26	3,24	3,6	3,2	3,73	3,5	3,47	3,41	3,47	3,41	3,34	3,43
Maximum current input	A	131	131	129	137	144	150	136	155	173	196	224	237	251	300
Starting current	A	330	330	245	389	396	266	252	310	330	380	403	468	476	497
No. of scroll compressors / circuits		2 / 2	2 / 1	4 / 2	2 / 2	2 / 1	4 / 2	4 / 2	4 / 2	4 / 2	4 / 2	4 / 2	4 / 2	4 / 2	4 / 2
No. of axial fans		8	8	8	8	8	8	6	6	6	6	8	8	8	8
Air flow rate	m ³ /h	39890	39890	39890	39890	39890	39890	67672	67672	67672	75478	103511	97902	97902	97902
Water flow rate (cooling)	l/h	23805	23805	24143	26660	26660	26378	27864	32095	35948	40747	46716	50827	53990	60257
Pressure drop, water side (cooling)	kPa	48	49	50	42	42	42	46	49	50	53	41	49	55	41
Available head, standard pump (cooling)	kPa	150	150	147	147	147	148	155	133	147	171	170	152	137	134
Buffer tank	dm ³	340	340	340	340	340	340	600	600	600	600	600	600	600	600
Expansion tank	dm ³	12	12	12	12	12	12	24	24	24	24	24	24	24	24
Plumbing connections		2 1/2	2 1/2	2 1/2	2 1/2	2 1/2	2 1/2	3	3	3	4	4	4	4	4
Height	mm	1735	1735	1679	1735	1735	1679	1847	1847	1847	2247	2330	2330	2330	2330
Length	mm	3190	3190	3540	3190	3190	3540	3538	3538	3538	3538	4206	4206	4206	4206
Depth	mm	1183	1183	1183	1183	1183	1183	1653	1653	1653	1653	1653	1653	1653	1653
Sound power level	dB(A)	82,0	86,0	82,0	82,0	86,0	82,0	87,0	87,0	87,0	87,0	88,0	88,0	88,0	84,0
Sound pressure level	dB(A)	54,0	58,0	54,0	54,0	58,0	54,0	59,0	59,0	59,0	59,0	60,0	60,0	60,0	56,0
Base unit operating weight	kg	1055	1055	1070	1085	1085	1220	1440	1460	1470	1620	1880	1912	1947	1947
Unit with pump and full tank operating weight	kg	1626	1626	1661	1656	1656	1811	2208	2276	2286	2469	2894	2926	2961	2961

Cooling capacity refers to the following conditions: water temperature 12-7°C; outdoor air temperature 35°C

Cooling capacity refers to the following conditions: water temperature 40-45°C, outdoor air temperature 7°C dry bulb and 6°C wet bulb

Sound pressure level refers to the following conditions: measured in an open field, at a distance of 10 m, with a directivity factor of 2.

Rated technical data of LCE heat pumps, LOW NOISE version															
Approx. capacity (kW)		45	50	60	70	80	90			100			120		
Efficiency Pack		2	2	2	2	2	1	2	4	1	2	4	1	2	4
LCE...HL		042	052	062	072	082	091	092	094	101	102	104	121	122	124
Power supply	V-ph-Hz	400-3-50													
Cooling capacity	kW	48	52,2	63,7	69,9	77,4	92,8	92,9	94,4	103,5	103,5	102,3	125	123,6	127,5
Total power input in cooling mode	kW	16,2	20,2	24	27	30,9	32	35	32,3	38,4	41,9	37,1	44,5	48,4	44,2
Rated current input	A	27,68	34,16	41,08	45,85	52,03	54,74	59,57	55,25	64,92	70,57	62,84	72,65	78,96	72,25
EER		2,96	2,58	2,65	2,59	2,51	2,9	2,65	2,92	2,7	2,47	2,76	2,81	2,55	2,88
ESEER		4,06	3,96	3,89	3,93	3,78	3,45	3,88	3,9	3,4	3,75	3,85	3,88	4,09	4,09
Heating capacity	kW	53,3	60,6	70,7	78,5	86,4	104,7	104,5	102,7	118	117,3	115,6	139,6	139,3	136,8
Total power input in heating mode	kW	15,5	17,9	19,6	22,4	25,6	30,5	30,1	30,3	35,4	34,8	35	43,8	43,4	43,4
Rated current input	A	26,58	30,47	33,98	38,39	43,53	52,32	51,68	51,99	60,19	59,17	59,51	71,55	70,96	70,83
COP		3,44	3,38	3,61	3,51	3,38	3,43	3,47	3,39	3,33	3,37	3,3	3,19	3,21	3,15
Maximum current input	A	41	44	51	55	66	77	77	81	86	86	87	95	95	96
Starting current	A	159	162	185	183	191	246	246	194	254	254	198	295	295	220
No. of scroll compressors / circuits		2 / 1	2 / 1	2 / 1	2 / 1	2 / 1	2 / 2	2 / 1	4 / 2	2 / 2	2 / 1	4 / 2	2 / 2	2 / 1	4 / 2
No. of axial fans		4	4	6	6	6	8	8	8	8	8	8	6	6	6
Air flow rate	m ³ /h	15398	15398	21955	21955	21955	29393	29393	29393	29393	29393	29393	43434	43434	43434
Water flow rate (cooling)	l/h	8261	8983	10956	12027	13313	15986	15986	16213	17778	17778	17582	21518	21518	21906
Pressure drop, water side (cooling)	kPa	26	31	47	35	43	31	32	32	39	39	38	40	40	41
Available head, standard pump (cooling)	kPa	157	149	125	131	117	129	129	128	118	118	119	107	107	105
Buffer tank	dm ³	200	200	220	220	220	340	340	340	340	340	340	600	600	600
Expansion tank	dm ³	12	12	12	12	12	12	12	12	12	12	12	24	24	24
Plumbing connections		2,00	2,00	2	2	2	2 1/2	2 1/2	2 1/2	2 1/2	2 1/2	2 1/2	3	3	3
Height	mm	1735	1735	1735	1735	1735	1735	1735	1679	1735	1735	1679	1847	1847	1847
Length	mm	2090	2090	2442	2442	2442	3190	3190	3540	3190	3190	3540	3538	3538	3538
Depth	mm	1183	1183	1183	1183	1183	1183	1183	1183	1183	1183	1183	1653	1653	1653
Sound power level	dB(A)	70,0	74,0	76,0	76,0	76,0	73,0	77,0	73,0	73,0	77,0	73,0	77,0	81,0	77,0
Sound pressure level	dB(A)	42,0	46,0	48,0	48,0	48,0	45,0	49,0	45,0	45,0	49,0	45,0	49,0	53,0	49,0
Base unit operating weight	kg	525	525	630	635	700	905	905	980	915	915	980	1260	1260	1275
Unit with pump and full tank operating weight	kg	862	862	982	987	1067	1426	1426	1557	1436	1436	1557	2040	2040	2055

Rated technical data of LCE heat pumps, LOW NOISE version															
Approx. capacity (kW)		140			160			170	190	210	240	270	290	320	
Efficiency Pack		1	2	4	1	2	4	4	4	4	4	4	4	4	
LCE...HL		141	142	144	161	162	164	ND	194	214	244	274	294	324	
Power supply	V-ph-Hz	400-3-50													
Cooling capacity	kW	137,4	137,7	139,7	155,4	155,7	153,7	-	180,8	211,9	230	265	287,1	304,2	
Total power input in cooling mode	kW	50,3	58,9	49,6	60,2	65,8	57,7	-	77,8	86,6	103,1	114,8	125,5	134,6	
Rated current input	A	81,98	95,69	80,89	97,85	106,84	93,85	-	126,01	140,25	166,7	184,71	201,78	216,44	
EER		2,73	2,34	2,82	2,58	2,37	2,66	-	2,33	2,45	2,23	2,31	2,29	2,26	
ESEER		3,93	4,01	4,1	3,61	3,79	3,75	-	3,84	3,84	3,94	3,91	4,05	4,18	
Heating capacity	kW	155,3	153,1	152,2	178,9	178,1	174,8	-	210,9	233,8	268,5	304,7	326,5	347,2	
Total power input in heating mode	kW	48	47,5	47,6	56,2	55,2	55,4	-	64,9	72,7	84,6	95,6	103,6	111,9	
Rated current input	A	78,35	77,54	77,57	91,42	82,02	90,14	-	105,42	117,89	136,92	153,79	166,69	179,98	
COP		3,23	3,22	3,2	3,18	3,23	3,16	-	3,25	3,22	3,19	3,19	3,158	3,1	
Maximum current input	A	106	106	105	120	120	126	-	148	167	190	215	229	242	
Starting current	A	306	306	222	371	371	241	-	307	318	382	398	464	472	
No. of scroll compressors / circuits		2 / 2	2 / 1	4 / 2	2 / 2	2 / 1	4 / 2	-	4 / 2	4 / 2	4 / 2	4 / 2	4 / 2	4 / 2	
No. of axial fans		6	6	6	6	6	6	-	6	6	6	8	8	8	
Air flow rate	m ³ /h	43434	43434	43434	40235	40235	40235	-	55808	63261	63261	87186	81687	81687	
Water flow rate (cooling)	l/h	23655	23655	24043	26719	26719	26434	-	31172	36451	36615	45628	49438	52350	
Pressure drop, water side (cooling)	kPa	48	49	50	43	43	43	-	47	51	39	46	52	52	
Available head, standard pump (cooling)	kPa	151	151	148	147	147	148	-	139	143	177	174	158	145	
Buffer tank	dm ³	600	600	600	600	600	600	-	600	600	600	600	600	600	
Expansion tank	dm ³	24	24	24	24	24	24	-	24	24	24	24	24	24	
Plumbing connections		3	3	3	3	3	3	-	3	4	4	4	4	4	
Height	mm	1847	1847	1847	1847	1847	1847	-	1847	2247	2247	2330	2330	2330	
Length	mm	3538	3538	3538	3538	3538	3538	-	3538	3538	3538	4206	4206	4206	
Depth	mm	1653	1653	1653	1653	1653	1653	-	1653	1653	1653	1653	1653	1653	
Sound power level	dB(A)	77,0	92,0	77,0	77,0	81,0	77,0	-	81,0	81,0	82,0	83,0	83,0	83,0	
Sound pressure level	dB(A)	49,0	64,0	49,0	49,0	53,0	49,0	-	53,0	53,0	54,0	55,0	55,0	55,0	
Base unit operating weight	kg	1310	1310	1290	1330	1330	1440	-	1460	1510	1620	1880	1912	1947	
Unit with pump and full tank operating weight	kg	2090	2090	2070	2110	2110	2220	-	2276	2326	2469	2894	2926	2961	

Cooling capacity refers to the following conditions: water temperature 12-7°C; outdoor air temperature 35°C

Cooling capacity refers to the following conditions: water temperature 40-45°C, outdoor air temperature 7°C dry bulb and 6°C wet bulb

Sound pressure level refers to the following conditions: measured in an open field, at a distance of 10 m, with a directivity factor of 2.

Rated technical data of LCE heat pumps, QUIET (super low noise) version															
Approx. capacity (kW)		45	50	60	70	80	90			100			120		
Efficiency Pack		2	2	2	2	2	1	2	4	1	2	4	1	2	4
LCE...HQ		042	052	062	072	082	091	092	094	101	102	104	121	122	124
Power supply	V-ph-Hz	400-3-50													
Cooling capacity	kW	48	52	64	70	77	93	93	94	104	104	102	124	124	126
Total power input in cooling mode	kW	16,2	20,2	24	27	30,9	32	35	32,3	38,4	38,7	37,1	45	47,1	45,1
Rated current input	A	27,68	34,16	41,08	45,85	52,03	54,74	59,57	55,25	64,92	65,39	62,84	73,45	76,84	73,59
EER		2,96	2,58	2,65	2,59	2,51	2,9	2,65	2,92	2,7	2,68	2,76	2,75	2,62	2,79
ESEER		4,06	3,96	3,89	3,93	3,78	3,45	3,88	3,9	3,4	3,75	3,85	3,88	4,15	4,09
Heating capacity	kW	53,3	60,6	70,7	78,5	86,4	104,7	104,5	102,7	118	117,3	115,6	135,5	123	133,3
Total power input in heating mode	kW	16	18	20	22	26	31	30	30	35	35	35	42	39	42
Rated current input	A	26,58	30,47	33,98	38,39	43,53	52,32	51,68	51,99	60,19	59,17	59,51	69,09	64,43	68,44
COP		3,44	3,38	3,61	3,51	3,38	3,43	3,47	3,39	3,33	3,37	3,3	3,21	3,13	3,18
Maximum current input	A	41	44	51	55	66	77	77	81	86	86	87	99	99	100
Starting current	A	159	162	185	183	191	246	246	194	254	254	198	299	299	225
No. of scroll compressors / circuits		2 / 1	2 / 1	2 / 1	2 / 1	2 / 1	2 / 2	2 / 1	4 / 2	2 / 2	2 / 1	4 / 2	2 / 2	2 / 1	4 / 2
No. of axial fans		4	4	6	6	6	8	8	8	8	8	8	6	6	6
Air flow rate	m ³ /h	15398	15398	21955	21955	21955	29393	29393	29393	29393	29393	29393	35930	35930	35930
Water flow rate (cooling)	l/h	8261	8983	10956	12027	13313	15986	15986	16213	17778	17778	17582	21259	21259	21623
Pressure drop, water side (cooling)	kPa	26	31	47	35	43	31	32	32	39	39	38	39	39	40
Available head, standard pump (cooling)	kPa	157	149	125	131	117	129	129	128	118	118	119	109	109	106
Buffer tank	dm ³	200	200	220	220	220	340	340	340	340	340	340	600	600	600
Expansion tank	dm ³	12	12	12	12	12	12	12	12	12	12	12	24	24	24
Plumbing connections		2	2	2	2	2	2 1/2	2 1/2	2 1/2	2 1/2	2 1/2	2 1/2	3	3	3
Height	mm	1735	1735	1735	1735	1735	1735	1735	1679	1735	1735	1679	1847	1847	1847
Length	mm	2090	2090	2442	2442	2442	3190	3190	3540	3190	3190	3540	3538	3538	3538
Depth	mm	1183	1183	1183	1183	1183	1183	1183	1183	1183	1183	1183	1653	1653	1653
Sound power level	dB(A)	67,0	71,0	73,0	73,0	73,0	70,0	74,0	70,0	70,0	70,0	74,0	70,0	69,0	73,0
Sound pressure level	dB(A)	39,0	43,0	45,0	45,0	45,0	42,0	46,0	42,0	42,0	42,0	46,0	42,0	41,0	45,0
Base unit operating weight	kg	525	525	630	635	700	905	905	980	915	915	980	1260	1260	1275
Unit with pump and full tank operating weight	kg	862	862	982	987	1067	1426	1426	1557	1436	1436	1557	2040	2040	2055

Rated technical data of LCE heat pumps, QUIET (super low noise) version															
Approx. capacity (kW)		140				160			170	190	210	240	270	290	320
Efficiency Pack		1	2	4	1	2	4	4	4	4	4	4	4	4	4
LCE...HQ		141	142	144	161	162	164	ND	194	214	244	274	294	324	
Power supply	V-ph-Hz	400-3-50													
Cooling capacity	kW	135,5	137,7	137,7	151,5	151,7	150,2	-	164,7	192,8	209,9	160,9	279	294,1	
Total power input in cooling mode	kW	51	56	51	62	68	59	-	89	100	109	116	128	138	
Rated current input	A	83,35	90,97	82,76	100,58	110,3	96,53	-	143,92	161,28	175,41	186,28	206,54	221,67	
EER		2,65	2,46	2,71	2,41	2,2	2,53	-	1,85	1,93	1,93	2,26	2,17	2,14	
ESEER		3,93	4,01	4,1	3,61	3,79	3,75	-	3,84	3,84	3,89	3,94	3,91	4,05	
Heating capacity	kW	151,3	150,1	148,3	173,2	173,1	171,3	-	204,9	226,8	262,6	296,7	318,5	338,2	
Total power input in heating mode	kW	47	42,4	46,3	54,7	50,1	54,1	-	63,5	71	82,9	94	101,7	109,7	
Rated current input	A	77	76	76	89	88	88	-	103	115	134	151	164	177	
COP		3,22	3,23	3,2	3,17	3,2	3,16	-	3,23	3,2	3,17	3,16	3,13	3,08	
Maximum current input	A	110	110	108	124	124	130	-	148	167	190	213	226	240	
Starting current	A	310	310	227	377	377	247	-	314	328	395	396	465	475	
No. of scroll compressors / circuits		2 / 2	2 / 1	4 / 2	2 / 2	2 / 1	4 / 2	-	4 / 2	4 / 2	4 / 2	4 / 2	4 / 2	4 / 2	
No. of axial fans		6	6	6	6	6	6	-	6	6	6	8	8	8	
Air flow rate	m ³ /h	35930	35930	35930	35930	35930	35930	-	35930	40953	40953	69835	69835	69835	
Water flow rate (cooling)	l/h	23303	23303	23667	26051	26051	25816	-	28282	33135	36054	44837	47938	50535	
Pressure drop, water side (cooling)	kPa	47	47	48	40	41	40	-	39	39	42	38	44	48	
Available head, standard pump (cooling)	kPa	153	153	151	151	151	152	-	161	171	193	177	164	153	
Buffer tank	dm ³	600	600	600	600	600	600	-	600	600	600	600	600	600	
Expansion tank	dm ³	24	24	24	24	24	24	-	24	24	24	24	24	24	
Plumbing connections		3	3	3	3	3	3	-	3	4	4	4	4	4	
Height	mm	1847	1847	1847	1847	1847	1847	-	1847	2247	2247	2330	2330	2330	
Length	mm	3538	3538	3538	3538	3538	3538	-	3538	3538	3538	4206	4206	4206	
Depth	mm	1653	1653	1653	1653	1653	1653	-	1653	1653	1653	1653	1653	1653	
Sound power level	dB(A)	69,0	73,0	69,0	69,0	73,0	69,0	-	73,0	73,0	73,0	74,0	74,0	74,0	
Sound pressure level	dB(A)	41,0	45,0	41,0	41,0	45,0	41,0	-	45,0	45,0	45,0	46,0	46,0	46,0	
Base unit operating weight	kg	1310	1310	1290	1330	1330	1440	-	1460	1510	1620	1880	1912	1947	
Unit with pump and full tank operating weight	kg	2090	2090	2070	2110	2110	2220	-	2276	2326	2469	2894	2926	2961	

Cooling capacity refers to the following conditions: water temperature 12-7°C; outdoor air temperature 35°C

Cooling capacity refers to the following conditions: water temperature 40-45°C, outdoor air temperature 7°C dry bulb and 6°C wet bulb

Sound pressure level refers to the following conditions: measured in an open field, at a distance of 10 m, with a directivity factor of 2.

LSE MULTI-SCROLL SOLUTIONS FOR HIGH PERFORMANCE UNDER PARTIAL LOAD CONDITIONS

Though a water chiller or heat pump is chosen on the basis of the maximum load of the system it is intended to serve, the actual thermal load of an air conditioning system is less than 60% of the rated load capacity 90% of the time.

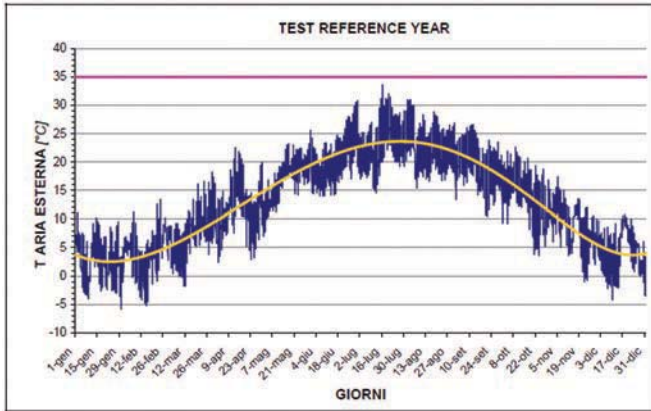

The **LSE** range of chillers and heat pumps includes 14 models with capacities from 370 to 1200 kW (650 kW in heat pump mode) and uses only scroll compressors on 2 or 4 cooling circuits.

HIGH EFFICIENCY UNDER PARTIAL LOAD CONDITIONS

The number of compressors, according to size, is 2 or 3 per cooling circuit, multiplying the capacity control steps.

The high number of capacity control steps enables the unit to adapt its power to the actual needs of the system, with particular gains in efficiency under partial load conditions compared to traditional screw compressors. The control microprocessor automatically distributes the workload among the compressors, thus increasing their lifespan.

During operation under partial load conditions, the compressors work with oversized exchange surfaces so as to achieve more advantageous thermodynamic cycles, thanks also to the use of an **electronic expansion valve, a standard feature of all models.**

VERSIONS

- Cooling Only
- Free-Cooling
- Heat pump, up to 650 kW

WATER PUMP OPTIONS

Complete hydronic kits can be incorporated within the units without modifying their size and you have the option of choosing the water circulation pump.

- Single pump, standard head or uprated (high head).
- Dual pumps, OR solution: standard head or uprated, operating singly. The pumps operate in turns on a time/fault basis.
- Dual pump, "AND" solution: standard or uprated pump, operating simultaneously.

Connected in parallel, they deliver water at the nominal flow rate when operating simultaneously.

Under partial load conditions operation is limited to a single pump, reducing the capacity by $\frac{1}{3}$ compared to the rated value and resulting in average savings of about 30% in pumping costs.

ACOUSTIC VERSIONS

S Standard execution

L Low-Noise execution for a low noise impact

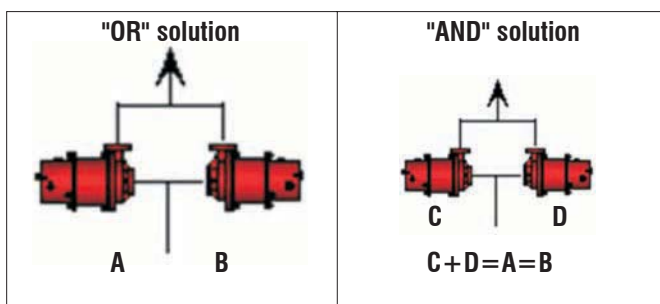

INTERCONNECTIVITY

With advanced microprocessor control it is possible to implement:

- LAN networks (up to 4 units)
- GSM kit for reading and setting data via a mobile phone
- WEB kit for reading and setting data remotely from a PC via access to the IP address of the chiller unit or network of units
- Serial cards for protocols:
 - Carel / Modbus
 - Lonworks / Trend
- WEB Hardware: Ethernet card for protocols:
 - Bacnet / SNMP
- WEB software: Ethernet board for Web interface



To request tenders for LSE chillers, fill in all the fields in the tender request form provided on the opposite page and send it to your local dealer. Below is a brief explanation of the items included in the form.

MODEL

- Identify the model on the table of the previous page depending on the required power

OPERATION

- C - cooling only
- H - reversible heat pump

VERSION

It is possible to choose from among 3 different acoustic configurations:

- **S** Standard execution
- **L** Low-Noise version for a low noise impact

POWER SUPPLY

- 400/3/50 + N
- 400/3/50 with 230V transformer for the auxiliary circuits
- 400/3/50 + N, circuit breakers
- 400/3/50 with 230V transformer 230V, circuit breakers

MICROPROCESSOR / EXPANSION VALVE

- **ADVANCED** + electronic valve
The chillers are designed to be equipped with an electronic expansion valve as a standard component. Chillers with traditional expansion valves can also be supplied on request.

WATER PUMP

- Absent
- Single pump and expansion tank
- Uprated single pump and expansion tank
- Dual pump for combined operation (AND operating logic) + expansion tank The management of AND logic requires the use of an **ADVANCED** microprocessor controller
- Uprated dual pump for combined operation (AND operating logic) + expansion tank The management of AND logic requires the use of an **ADVANCED** microprocessor controller
- Dual pump with rotation on a time basis (OR logic) and expansion tank (rotation on a time basis)
- Dual uprated pump in time sequence (OR operating sequence) and expansion tank

BUFFER TANK

- Absent
- Present, integrated into the unit without modifying its overall dimensions, located on the outlet side in standard configurations.

HEAT RECOVERY

- Absent
- Partial (desuperheater) In that case, the presence of a condensation control system is mandatory.

CONDENSATION CONTROL

- Absent
- Phase cut modulating control with adjustment of air flow rate depending on the condensation pressure. Using this option enables the unit to operate in the cooling mode with air temperatures below 20°, down to a temperature of as low as -10°C.

ANTIFREEZE KIT

- Absent
- Present, units with evaporator only
- Present, units with evaporator, pump and expansion tank
- Present, units with evaporator, pump, expansion tank and buffer tank

REMOTE COMMUNICATION

- Absent
- RS485 Serial board (Modbus or Carel protocol)
- Lonworks serial care (option available only if an **ADVANCED** microprocessor controller is used)
- GSM modem kit for communication via SMS messages
- Ethernet pCOWEB board (SNMP or BACNET protocol)
- Ethernet pCOWEB board (SNMP or BACNET protocol) + HIWEB supervision software

COOLING ACCESSORIES

- Absent
- Pressure gauges

SPECIAL HEAT EXCHANGER CONFIGURATION (ON REQUEST)

- Standard
- Copper / copper heat exchangers
- Heat exchangers with cataphoresis
- Heat exchangers with corrosion-proof treatment
- Special

PACKING

- Standard
- Wooden crate
- Wooden case

INSULATION

- Absent
- Base rubber vibration dumpers
- Base spring vibration dumpers

REMOTE CONTROLLER

- Absent
- Simplified
- Base microprocessor control
- Advanced microprocessor control

INSTALLATION OF THE UNIT

- Absent
- Pair of quick couplings for water IN-OUT

ACCESSORIES

- Power factor correction capacitors
- Soft-starter kit
- Service kit (kit of sensors for quick diagnosis)
- Clock card
- ON/OFF status of the compressors
- Remote control for limiting compressor starts
- Configurable digital alarm card
- Outdoor air temperature probe for setpoint compensation
- Pressure gauges
- Regulating filter kit (solenoid and tap on the liquid line)
- Normative reference other than "97/23/EC - PED"
- Condenser protection grille

RATED TECHNICAL DATA of LSE water chillers, CS version																	
LSE...CS		374	416	456	486	536	558	618	658	748	800	900	942	1072	1202		
Power supply	V-ph-Hz	400V - 3 Ph - 50 Hz															
Cooling capacity	kW	366,80	413,02	454,74	488,19	532,46	562,83	615,96	657,31	734,91	799,89	898,06	950,95	1.062,94	1.202,00		
Total power input	kW	124,55	149,91	158,31	173,24	192,65	194,22	212,14	229,64	248,56	291,73	310,07	345,30	382,66	453,80		
EER		2,95	2,75	2,87	2,82	2,76	2,90	2,90	2,86	2,96	2,74	2,90	2,75	2,78	2,67		
ESEER		4,26	4,18	4,32	4,25	4,23	4,15	4,15	4,09	4,15	4,19	4,33	4,34	4,29	4,28		
Total absorbed current	A	221,32	278,17	289,93	305,96	338,46	368,53	386,89	404,79	441,86	511,81	549,74	606,69	669,51	741,7		
FLA Maximum absorbed current (without accessories)	A	270	333	362	382	400	453	480	506	540	631	670	755	792	975		
LRA Inrush current (without accessories)	A	432	476	550	558	518	569	637	648	613	738	699	828	777	1190		
No. of scroll compressors / circuits		4/2	6/2	6/2	6/2	6/2	8/4	8/4	8/4	8/4	10/4	10/4	12/4	12/4	12/4		
No. of axial fans		6			8			10			12			14		16	
Air flow rate	m³/h	118.913			159.453			209.054			199.974	251.304	245.895	280.994		320.000	
Water flow rate	l/h	63.090	71.039	78.215	83.968	91.584	96.807	105.944	113.057	126.404	137.581	154.467	163.564	182.825	208.136		
Pressure drop, water side	kPa	54	56	57	51	52	46	50	52	53	63	55	61	51	56		
Head available - Pumps (OR) BP (option)	kPa	154	125	176	160	128	151	125	191	155	114	180	162	147	115		
Head available - Pumps (OR) HP (option)	kPa	252	236	262	257	241	235	234	227	253	234	276	259	244	214		
Head available - Pumps (AND) LP (option)	kPa	164	143	124	114	92	160	144	133	153	126	181	158	130	86		
Head available - Pumps (AND) HP (option)	kPa	237	226	217	216	205	280	263	252	230	233	266	251	242	219		
Buffer tank	dm³	600						1040									
Expansion tank	dm³	50															
Vic Taulic water connections	inches	4						5				6					
Height	mm	2.650			2.650			2.650			2.650			2.650		2650	
Length	mm	3.065			4.065			5.065			6.065			7.065		8065	
Depth	mm	2.250			2.250			2.250			2.250			2.250		2250	
Sound power level Lw	dB(A)	90			91			92			92			93		95	
Sound pressure level Lp	dB(A)	62			63			64			64			65		67	
Weight without accessories	kg	2.545	2.990	3.361	3.385	3.386	4.132	4.217	4.482	4.891	5.090	5.688	5.926	6.066	7300		
RATED TECHNICAL DATA of LSE water chillers, CL version (low-noise)																	
LSE...CL		374	416	456	486	536	558	618	658	748	800	900	942	1072	1202		
Power supply	V-ph-Hz	400V - 3 Ph - 50 Hz															
Cooling capacity	kW	354,49	394,97	440,09	470,82	512,49	546,51	593,81	632,01	712,75	765,47	868,05	912,48	1.018,58	1.177,00		
Total power input	kW	126,95	154,67	160,50	176,58	197,61	196,17	216,16	235,28	252,28	300,85	317,33	356,02	396,71	466,50		
EER		2,79	2,55	2,74	2,67	2,59	2,79	2,75	2,69	2,82	2,54	2,73	2,56	2,57	2,52		
ESEER		4,19	4,11	4,25	4,18	4,16	4,07	4,08	4,02	4,08	4,12	4,26	4,27	4,22	4,28		
Total absorbed current	A	218,86	277,84	284,61	302,87	337,52	360,1	382,08	403	435,43	513,16	546,3	608,18	675,32	766,3		
FLA Maximum absorbed current (without accessories)	A	259	322	347	368	386	435	462	488	518	518	645	730	767	975		
LRA Inrush current (without accessories)	A	421	465	545	543	504	551	619	630	592	592	674	803	752	1190		
No. of scroll compressors / circuits		4/2	6/2	6/2	6/2	6/2	8/4	8/4	8/4	8/4	10/4	10/4	12/4	12/4	12/4		
No. of axial fans		4 / 2	6 / 2	6 / 2	6 / 2	6 / 2	8 / 4	8 / 4	8 / 4	8 / 4	10 / 2	10 / 2	12 / 2	14	16		
Air flow rate	m³/h	94.300			126.557			167.300	163.050	158.800	201.182	196.109	223.266	213.120	280.000		
Water flow rate	l/h	60.972	67.935	75.696	80.981	88.148	94.000	102.135	108.706	122.594	131.662	149.304	156.947	175.195	202.208		
Pressure drop, water side	kPa	50	51	53	48	47	44	47	48	51	57	51	56	47	53		
Head available - Pumps (OR) BP (option)	kPa	164	140	189	175	147	160	138	206	168	136	190	176	161	127		
Head available - Pumps (OR) HP (option)	kPa	259	246	271	266	252	244	241	234	259	245	285	271	258	225		
Head available - Pumps (AND) LP (option)	kPa	172	155	134	126	106	167	153	143	162	141	194	175	149	101		
Head available - Pumps (AND) HP (option)	kPa	243	234	224	223	214	286	272	262	239	244	274	262	254	228		
Buffer tank	dm³	600						1.040									
Expansion tank	dm³	50															
Vic Taulic water connections	inches	4						5				6					
Height	mm	2.650			2.650			2.650			2.650			2.650		2650	
Length	mm	3.065			4.065			5.065			6.065			7.065		8065	
Depth	mm	2.250			2.250			2.250			2.250			2.250		2250	
Sound power level Lw	dB(A)	82			83			84			85			85		92	
Sound pressure level Lp	dB(A)	54			55			56			57			57		64	
Weight without accessories	kg	2650	3110	3481	3525	3526	4312	4397	4662	4996	5195	5928	6.166	6.406	7300		

Cooling: outdoor air temperature 35°C, evaporator water temperature 12°C / 7°C
 Sound power measured according to standards ISO 3741 - ISO 3744 and EN 29614-1
 Sound pressure level measured at a distance of 10 m with a directivity factor of 2

RATED TECHNICAL DATA of LSE heat pumps, HS version (standard)

LSE...HS		374	416	456	486	536	558	618	658	
Power supply	V-ph-Hz	400V - 3 Ph - 50 Hz								
Cooling capacity	kW	366,8	413,02	454,74	488,19	532,46	562,83	615,96	657,31	
Total power input	kW	124,55	149,91	158,31	173,24	192,65	194,22	212,14	229,64	
EER		2,95	2,75	2,87	2,82	2,76	2,9	2,9	2,86	
ESEER		4,26	4,18	4,32	4,25	4,23	4,15	4,15	4,09	
Total absorbed current	A	221,32	278,17	289,93	305,96	338,46	368,53	386,89	404,79	
Heating capacity	kW	410,18	470,15	513,77	550,81	602,15	647,83	695,88	743,92	
Total power input	kW	119,44	139,77	153,63	163,39	175,67	189,49	203,84	218,18	
COP		3,43	3,36	3,34	3,37	3,43	3,42	3,41	3,41	
Total absorbed current	A	214,13	265,77	284,07	292,93	314,21	325,1	348,63	372,15	
FLA Maximum absorbed current (without accessories)	A	270	333	362	382	400	453	480	506	
LRA Inrush current (without accessories)	A	432	476	550	558	518	569	637	648	
No. of scroll compressors / circuits		4/2	6/2	6/2	6/2	6/2	8/4	8/4	8/4	
No. of axial fans		6		8			10			
Air flow rate	m³/h	118.913		159.453			209.054		199.974	
Water flow rate in cooling mode	l/h	63.090	71.039	78.215	83.969	91.583	96.807	105.945	113.057	
Pressure drop, water side (cooling)	kPa	54	56	57	51	52	46	50	52	
Head available (cooling) - Pumps (OR) LP	kPa	154	125	176	160	128	151	125	191	
Head available (cooling) - Pumps (OR) HP	kPa	252	236	262	257	241	235	234	227	
Head available (cooling) - Pumps (AND) LP	kPa	164	143	124	114	92	160	144	133	
Head available (cooling) - Pumps (AND) HP	kPa	237	226	217	216	205	280	263	252	
Buffer tank	dm³	600					1040			
Expansion tank	dm³	50								
Vic Taulic water connections	inches	4					5			
Height	mm	2.650		2.650			2.650			
Length	mm	3.065		4.065			5.065			
Depth	mm	2.250		2.250			2.250			
Sound power level Lw	dB(A)	82		83			84			
Sound pressure level Lp	dB(A)	62		63			64			
Weight without accessories	kg	2.685	3.130	3.501	3.545	3.546	4.382	4.467	4.682	

Cooling: outdoor air temperature 35°C, evaporator water temperature 12°C / 7°C
 Heating: outdoor air temperature 7°C, condenser water temperature 40°C / 45°C
 Sound power measured according to standards ISO 3741 - ISO 3744 and EN 29614-1
 Sound pressure level measured at a distance of 10 m with a directivity factor of 2

RATED TECHNICAL DATA of LSE heat pumps, HL version (low-noise)									
LSE...HL		374	416	456	486	536	558	618	658
Power supply	V-ph-Hz	400V - 3 Ph - 50 Hz							
Cooling capacity	kW	354,49	394,97	440,09	470,82	512,49	546,51	593,81	632,01
Total power input	kW	126,95	154,67	160,5	176,58	197,61	196,17	216,16	235,28
EER		2,79	2,55	2,74	2,67	2,59	2,79	2,75	2,69
ESEER		4,19	4,11	4,25	4,18	4,16	4,07	4,08	4,02
Total absorbed current	A	218,86	277,84	284,61	302,87	337,52	360,1	382,08	403
Heating capacity	kW	408,39	467,43	510,81	547,78	598,87	644,83	692,34	739,86
Total power input	kW	115,88	136,23	148,9	158,52	170,91	183,59	197,83	212,08
COP		3,52	3,43	3,43	3,46	3,5	3,51	3,5	3,49
Total absorbed current	A	203,3	254,97	269,67	278,34	299,74	307,1	330,45	353,83
FLA Maximum absorbed current (without accessories)	A	259	322	347	368	386	435	462	488
LRA Inrush current (without accessories)	A	421	465	545	543	504	551	619	630
No. of scroll compressors / circuits		4/2	6/2	6/2	6/2	6/2	8/4	8/4	8/4
No. of axial fans		6		8			10		
Air flow rate	m ³ /h	94.300		126.557			167.300	163.050	158.800
Water flow rate in cooling mode	l/h	60.972	67.935	75.696	80.981	88.148	94.000	102.135	108.706
Pressure drop, water side	kPa	50	51	53	48	47	44	47	48
Head available (cooling) - Pumps (OR) LP	kPa	164	140	189	175	147	160	138	206
Head available (cooling) - Pumps (OR) HP	kPa	259	246	271	266	252	244	241	234
Head available (cooling) - Pumps (AND) LP	kPa	172	155	134	126	106	167	153	143
Head available (cooling) - Pumps (AND) HP	kPa	243	234	224	223	214	286	272	262
Buffer tank	dm ³	600					1.040		
Expansion tank	dm ³	50							
Vic Taulic water connections	inches	4					5		
Height	mm	2.650		2.650			2.650		
Length	mm	3.065		4.065			5.065		
Depth	mm	2.250		2.250			2.250		
Sound power level Lw	dB(A)	82		83			84		
Sound pressure level Lp	dB(A)	54		55			56		
Weight without accessories	kg	2.790	3.250	3.621	3.665	3.666	4.562	4.647	4.912

Cooling: outdoor air temperature 35°C, evaporator water temperature 12°C / 7°C

Heating: outdoor air temperature 7°C, condenser water temperature 40°C / 45°C

Sound power measured according to standards ISO 3741 - ISO 3744 and EN 29614-1

Sound pressure level measured at a distance of 10 m with a directivity factor of 2

WATER COOLED CHILLERS AND HEAT PUMPS

- > LEW C-H WATER-COOLED UNITS
- > OCCUPY A SMALL SURFACE AREA
- > NO NEED TO ADD GLYCOL TO THE WATER IN THE USER CIRCUIT
- > HIGH COP OF THE THERMODYNAMICAL CYCLE
- > NO NOISE OUTSIDE
- > REDUCED REFRIGERANT CHARGE
- > INNOVATIVE AESTHETICS AND TOTAL SAFETY, GIVEN THAT THE CHILLERS ARE COMPLETELY ENCLOSED
- > OPTION OF INSTALLING AN OUTDOOR DRY COOLER WHERE IT IS NOT POSSIBLE TO USE A NON-RECIRCULATING WATER SUPPLY TO COOL THE CONDENSER
- > HEAT PUMP VERSION WITH CYCLE REVERSIBILITY AT THE COOLING SIDE
- > CONDENSING CONTROL OPTION ON THE HEAT PUMP VERSIONS POSSIBLE

> VERSION

- C** Chiller Cooling only, dissipation with well or mains water
- D** Chiller Cooling only, dissipation with cooling tower water or dry cooler
- H** Reversible heat pump
- W** Irreversible heat pump

> EFFICIENCY PACK

The possibility of setting up different cooling circuits in units of the same power means being able to personalise efficiency levels under full or partial load conditions.

- 1 Dual circuit / dual compressor
The dual circuit-dual compressor models provide high efficiency values under full load (EER and COP).
- 2 Single circuit / dual compressor
The solution of using two compressors in a single cooling circuit increases efficiency under partial load conditions, reaching ESEER values greater than 4.
- 2 Single circuit / three compressors
the best solution for applications demanding cost-effectiveness and efficiency under partial load conditions
- 4 Dual circuit / 4 compressors
4 compressors enable the unit to output power in 4 steps and adapt perfectly to the actual thermal load of the system. The redundancy of cooling circuits and compressors is a guarantee of reliability.

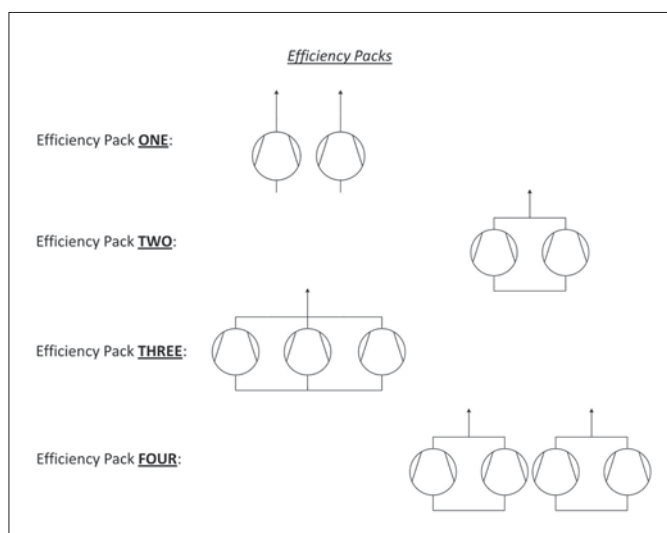

S Standard execution

L Low-Noise execution for a low noise impact

GENERALITIES

The LEW series of water-cooled chillers includes a range of models capable of satisfying every need.

The LEW units are designed to cool-heat water and solutions containing up to 30% glycol (percentage by weight) in civil, industrial and technological air-conditioning systems.

In buildings with large surface areas, the air conditioning system can be expanded step by step as new floors or areas are sold/leased, by installing an LEW unit for every floor in a small control room. This allows you to spread your investment over time.

The possibility of keeping the evaporator indoors means there is no need to add glycol to the water inside the system. In addition, you can keep all components requiring maintenance in an easily accessible room.

STRUCTURE

All LEW units are built with a galvanised sheet steel supporting base and enclosing panels coated with epoxy powder paint oven cured at 180°C. The unit boasts an exclusive design which lends it an attractive appearance as well as assuring the complete inaccessibility of all components when the unit is closed: this aspect, combined with the ample use of sound-deadening material inside the compartment, an optional feature of the low-noise version, reduces the level of sound power emitted to exceptionally low levels [Lp < 66 dB-A @1 metre].

The plumbing connections are provided on the side of the unit.

All panels are removable to permit full access to the unit components even though only the front access is required for maintenance operations.

COOLING CIRCUIT

The entire cooling circuit is built using only components of the finest quality brands and processes conforming to the specifications of Directive 97/23 for brazing.

The chillers are built with a single or dual cooling circuit using only components supplied by leading international manufacturers.

COMPRESSORS

Only Scroll-type compressors of leading international manufacturers are used in the LEW units.

Today Scroll compressors represent the best solution capable of ensuring reliability and efficiency in the range of powers up to 182 kW per circuit and the best solution for keeping down noise levels.



HEAT EXCHANGERS

All units have heat exchangers with braze-welded AISI 316 austenitic stainless steel plates and connections made of AISI 316 L, characterised by a reduced carbon content to facilitate brazing.



Braze-welded plate exchangers represent the state of the art in terms of heat exchange efficiency and make it possible to significantly reduce the refrigerant charge compared to traditional solutions.

The high turbulence induced by the internal corrugation of the plates combined with their perfectly smooth surface also helps prevent dirt build-up and the formation of scale on the condenser side.

COOLING COMPONENTS

- Molecular mesh activated-alumina filter dryer
- Flow indicator with humidity indicator. Indications are provided directly on the sight glass.
- Electronically controlled electric expansion valve
- Electric thermostatic valve with stepper motor and dedicated electronic driver designed to maximise the efficiency of the cooling circuit and optimise the operating parameters.
- Cycle-reversing valve (heat pump models only)
- Check valves (heat pump models only)
- High and low pressure switches
- Schrader valves for checks, access and/or maintenance
- Safety valve, refrigerant side

ELECTRIC CONTROL BOARD

The electric control board is constructed and wired in accordance with Directives 73/23/EEC and 89/336/EEC and related standards.

The board may be accessed through a door after the main switch has been put off.

All the remote controls use 24 V signals powered by an insulating transformer situated on the electric control board.

A temperature control kit comprising a thermostat and an auxiliary fan is available on request.

The protection rating of the unit is IP 43.



CONTROL MICROPROCESSOR

Available in a basic and advanced version, the onboard microprocessor of the chiller allows the various operating parameters to be controlled via a keypad on the electrical control board:

- Switching on/off of compressor to maintain the temperature set point of the chiller inlet water temperature
- Alarm management
 - High / low pressure
 - Antifreeze
 - Flow switch
 - Pump alarm
- Alarm signalling
- Display of operating parameters
- Anti-frost protection of evaporator
- Control of maximum number of compressor starts
- RS232, RS485 serial output management (optional)

Phase sequence error [Not displayed by the μ P, but prevents the compressor from starting up]

RATED TECHNICAL DATA OF LEW WATER CHILLERS											
Approx. capacity (kW)		50		60		70		80		90	
Efficiency pack		1	2	1	2	1	2	1	2	1	2
LEW CS / CL		041	042	051	052	061	062	071	072	081	082
Cooling capacity	kW	51,94	51,11	60,23	60,14	69,12	69,17	77,94	77,91	89,13	89,11
Rated input power	kW	9,27	8,65	11,18	11,19	12,37	12,37	14,27	14,28	15,86	15,86
EER		5,60	5,91	5,39	5,37	5,59	5,59	5,46	5,46	5,62	5,62
Pressure drops, evaporator side	kPa	38	37	51	51	40	40	50	50	39	39
Pressure drops - condenser side	kPa	7	7	9	9	12	12	15	15	18	18
Power supply	V - ph - Hz	400 - 3N - 50Hz									
Scroll compressors / cooling circuits	No.	2 / 2	2 / 1	2 / 2	2 / 1	2 / 2	2 / 1	2 / 2	2 / 1	2 / 2	2 / 1
Water connections VIC-TAULIC type	inches	2 1/2	2 1/2	2 1/2	2 1/2	2 1/2	2 1/2	2 1/2	2 1/2	2 1/2	2 1/2
Height	mm	1.594	1.594	1.594	1.594	1.594	1.594	1.594	1.594	1.594	1.594
Length	mm	1.174	1.174	1.174	1.174	1.174	1.174	1.174	1.174	1.174	1.174
Depth	mm	772	772	772	772	772	772	772	772	772	772
LEW-CS: Sound power level	dB(A)	69	69	69	69	69	69	70	70	70	70
LEW-CL: Sound power level	dB(A)	67	67	67	67	67	67	68	68	68	68

RATED TECHNICAL DATA OF LEW WATER CHILLERS											
Approx. capacity (kW)		100		120		130		150			
Efficiency pack		1	2	1	2	1	2	1	2	4	
LEW CS / CL		091	092	111	112	131	132	141	142	144	
Cooling capacity	kW	99,27	99,28	118,88	118,92	135,62	135,52	157,2	157,33	156,88	
Rated input power	kW	18,03	18,04	21,33	21,34	24,64	24,64	27,9	27,86	28,81	
EER		5,51	5,50	5,57	5,57	5,50	5,50	5,63	5,65	5,45	
Pressure drops, evaporator side	kPa	48	48	39	39	50	50	47	47	47	
Pressure drops - condenser side	kPa	22	22	30	30	38	38	19	19	19	
Power supply	V - ph - Hz	400 - 3N - 50Hz									
Scroll compressors / cooling circuits	No.	2 / 2	2 / 1	2 / 2	2 / 1	2 / 2	2 / 1	2 / 2	2 / 1	2 / 2	
Water connections VIC-TAULIC type	inches	2 1/2	2 1/2	2 1/2	2 1/2	2 1/2	2 1/2	2 1/2	2 1/2	2 1/2	
Height	mm	1.594	1.594	1.594	1.594	1.594	1.594	1.594	1.594	1.854	
Length	mm	1.174	1.174	1.674	1.674	1.674	1.674	1.674	1.674	2.374	
Depth	mm	772	772	772	772	772	772	772	772	877	
LEW-CS: Sound power level	dB(A)	70	70	71	71	71	71	73	73	73	
LEW-CL: Sound power level	dB(A)	68	68	69	69	69	69	71	71	71	

Cooling capacity refers to the following conditions: water temperature at evaporator 12/7°C – water temperature at condenser 15 - 30°C
 Heating capacity: water temperature at evaporator 15-10°C, water temperature at condenser 40 - 45°C.
 Sound power measured according to standards ISO 3741 - ISO 3744 and EN 29614-1

RATED TECHNICAL DATA OF LEW WATER CHILLERS												
Approx. capacity (kW)		170			200			220	230	270		
Efficiency pack		1	2	4	1	2	4	4	4	3	4	
LEW CS / CL		161	162	164	181	182	184	204	214	243	244	
Cooling capacity	kW	174,86	175,08	176,18	204,53	204,76	198,9	219,07	235,14	267,91	278,95	
Rated input power	kW	32,05	32,05	31,89	37,85	37,88	36,4	39,34	42,66	47,75	47,88	
EER		5,46	5,46	5,52	5,40	5,41	5,46	5,57	5,51	5,61	5,83	
Pressure drops, evaporator side	kPa	51	51	52	54	54	51	51	57	51	55	
Pressure drops - condenser side	kPa	23	23	23	30	31	29	28	33	21	23	
Power supply	V - ph - Hz	400 - 3N - 50Hz										
Scroll compressors / cooling circuits	No.	2 / 1	2 / 2	2 / 1	2 / 2	2 / 1	4 / 2	4 / 2	4 / 2	3 / 1	4 / 2	
Water connections VIC-TAULIC type	inches	2 1/2	2 1/2	2 1/2	2 1/2	2 1/2	2 1/2	2 1/2	2 1/2	2 1/2	2 1/2	
Height	mm	1.594	1.594	1.854	1.594	1.594	1.854	1.854	1.854	1.854	1.854	
Length	mm	1.674	1.674	2.374	1.674	1.674	2.374	2.374	2.374	2.374	2.374	
Depth	mm	772	772	877	772	772	877	877	877	877	877	
LEW-CS: Sound power level	dB(A)	73	73	73	73	73	73	73	73	73	73	
LEW-CL: Sound power level	dB(A)	71	71	71	71	71	71	71	71	71	71	
RATED TECHNICAL DATA OF LEW WATER CHILLERS												
Approx. capacity (kW)		310		350	370	410	450	480	480	530	570	630
Efficiency pack		3	4	4	4	4	4	4	n.a.	n.a.	n.a.	n.a.
LEW CS / CL		283	284	314	344	374	424	484	485	535	576	636
Cooling capacity	kW	312,96	316,39	349,67	377,36	410,6	453,5	520,7	506,6	574,7	612,3	681,1
Rated input power	kW	56,44	56,32	64,69	70,4	74,47	81,62	92,5	93,9	104,4	114	126,9
EER		5,55	5,62	5,41	5,36	5,51	5,56	5,63	5,4	5,5	5,37	2,37
Pressure drops, evaporator side	kPa	40	41	49	56	54	56	53	53	55	53	65
Pressure drops - condenser side	kPa	28	28	35	36	33	33	39	23	28	32	39
Power supply	V - ph - Hz	400 - 3N - 50Hz										
Scroll compressors / cooling circuits	No.	3 / 1	4 / 2	4 / 2	4 / 2	4 / 2	4 / 2	4 / 2	5 / 2	5 / 2	6 / 2	5 / 2
Water connections VIC-TAULIC type	inches	3	3	3	3	3	3	3	5	5	5	5
Height	mm	1.854	1.854	1.854	1.854	1.854	1.854	1854	1490	1490	1490	1490
Length	mm	2.374	2.374	2.374	2.374	2.374	2.374	2374	3530	3530	3530	3530
Depth	mm	877	877	877	877	877	877	877	1200	1200	1200	1200
LEW-CS: Sound power level	dB(A)	73	73	73	75	75	75	86	84	84	85	85
LEW-CL: Sound power level	dB(A)	71	71	71	73	73	73	82	80	80	81	81

Cooling capacity refers to the following conditions: water temperature at evaporator 12/7°C – water temperature at condenser 15 - 30°C

Heating capacity: water temperature at evaporator 15-10°C, water temperature at condenser 40 - 45°C.

Sound power measured according to standards ISO 3741 - ISO 3744 and EN 29614-1

LEW HEAT PUMPS RATED TECHNICAL DATA											
Approx. capacity (kW)		50		60		70		80		90	
Efficiency pack		1	2	1	2	1	2	1	2	1	2
LEW HS / HL		041	042	051	052	061	062	071	072	081	082
Cooling capacity	kW	51,94	51,11	60,23	60,14	69,72	69,73	78,34	78,51	90,38	90,45
Rated input power	kW	9,27	8,65	11,18	11,19	12,17	12,17	14,06	14,04	15,34	15,34
EER		5,60	5,91	5,39	5,37	5,73	5,73	5,57	5,59	5,89	5,90
Pressure drops, user side	kPa	37	36	50	50	52	52	49	49	39	39
Pressure drops, dissipator side	kPa	5	5	7	7	6	6	7	7	5	5
Heating capacity	kW	60,17	59	70,91	70,9	80,5	80,52	91,69	91,72	104,38	104,38
Rated input power	kW	12,8	12,13	15,29	15,3	16,85	16,85	19,46	19,47	21,42	21,43
COP		4,70	4,86	4,64	4,63	4,78	4,78	4,71	4,71	4,87	4,87
Pressure drops, user side	kPa	47	45	65	65	49	49	64	64	49	49
Pressure drops, dissipator side	kPa	32	31	44	44	44	44	43	43	33	33
Power supply	V - ph - Hz	400 - 3N - 50Hz									
Scroll compressors / cooling circuits	No.	2 / 2	2 / 1	2 / 2	2 / 1	2 / 2	2 / 1	2 / 2	2 / 1	2 / 2	2 / 1
Water connections VIC-TAULIC type	inches	2 1/2	2 1/2	2 1/2	2 1/2	2 1/2	2 1/2	2 1/2	2 1/2	2 1/2	2 1/2
Height	mm	1.594	1.594	1.594	1.594	1.594	1.594	1.594	1.594	1.594	1.594
Length	mm	1.174	1.174	1.174	1.174	1.174	1.174	1.174	1.174	1.174	1.174
Depth	mm	772	772	772	772	772	772	772	772	772	772
LEW-HS: Sound power level	dB(A)	69	69	69	69	69	69	70	70	70	70
LEW-HL: Sound power level	dB(A)	67	67	67	67	67	67	68	68	68	68

LEW HEAT PUMPS RATED TECHNICAL DATA											
Approx. capacity (kW)		100		120		130		150			
Efficiency pack		1	2	1	2	1	2	1	2	4	
LEW HS / HL		091	092	111	112	131	132	141	142	144	
Cooling capacity	kW	100,82	100,97	122,01	122,07	139,04	139,22	155,73	159,54	159,28	
Rated input power	kW	17,42	17,41	20,17	20,16	23,24	23,22	27,01	27,01	27,92	
EER		5,79	5,80	6,05	6,06	5,98	6,00	5,77	5,91	5,70	
Pressure drops, user side	kPa	49	49	42	42	52	52	49	49	48	
Pressure drops, dissipator side	kPa	7	7	6	6	7	7	7	7	7	
Heating capacity	kW	140,29	140,31	140,29	140,31	160,24	160,28	184,3	184,18	185,49	
Rated input power	kW	28,56	28,55	28,56	28,55	33,19	33,16	37,89	37,87	38,71	
COP		4,91	4,91	4,91	4,91	4,83	4,83	4,86	4,86	4,79	
Pressure drops, user side	kPa	61	61	50	50	64	64	60	60	61	
Pressure drops, dissipator side	kPa	42	42	36	36	44	44	42	42	42	
Power supply	V - ph - Hz	400 - 3N - 50Hz									
Scroll compressors / cooling circuits	No.	2 / 2	2 / 1	2 / 2	2 / 1	2 / 2	2 / 1	2 / 2	2 / 1	4 / 2	
Water connections VIC-TAULIC type	inches	2 1/2	2 1/2	2 1/2	2 1/2	2 1/2	2 1/2	2 1/2	2 1/2	2 1/2	
Height	mm	1.594	1.594	1.594	1.594	1.594	1.594	1.594	1.594	1.854	
Length	mm	1.174	1.174	1.674	1.674	1.674	1.674	1.674	1.674	2.374	
Depth	mm	772	772	772	772	772	772	772	772	877	
LEW-HS: Sound power level	dB(A)	70	70	71	71	71	71	73	73	73	
LEW-HL: Sound power level	dB(A)	68	68	69	69	69	69	71	71	71	

Cooling capacity refers to the following conditions: water temperature at evaporator 12/7°C – water temperature at condenser 15 - 30°C
 Heating capacity: water temperature at evaporator 15-10°C, water temperature at condenser 40 - 45°C.
 Sound power measured according to standards ISO 3741 - ISO 3744 and EN 29614-1

LEW HEAT PUMPS RATED TECHNICAL DATA												
Approx. capacity (kW)		170			200			220	230	270		
Efficiency pack		1	2	4	1	2	4	4	4	3	4	
LEW HS / HL		161	162	164	181	182	184	204	214	243	244	
Cooling capacity	kW	177,95	177,84	179,33	212,16	212,16	206,42	223,93	244,76	276,41	288,36	
Rated input power	kW	30,93	30,95	30,76	35,9	35,9	34,44	37,51	40,28	45,77	45,8	
EER		5,75	5,75	5,83	5,91	5,91	5,99	5,97	6,08	6,04	6,30	
Pressure drops, user side	kPa	54	54	54	48	48	46	53	50	53	35	
Pressure drops, dissipator side	kPa	7	7	8	7	7	6	7	7	8	4	
Heating capacity	kW	206,27	206,37	207,12	244,39	244,28	237,95	257,95	281,31	318,04	329,52	
Rated input power	kW	42,83	42,82	43,08	49,94	49,95	48,24	52,89	57	63,37	65,38	
COP		4,82	4,82	4,81	4,89	4,89	4,93	4,88	4,94	5,02	5,04	
Pressure drops, user side	kPa	66	66	67	58	58	56	66	63	67	39	
Pressure drops, dissipator side	kPa	46	46	46	41	41	40	45	43	47	30	
Power supply	V - ph - Hz	400 - 3N - 50Hz										
Scroll compressors / cooling circuits	No.	2 / 2	2 / 1	4 / 2	2 / 2	2 / 1	4 / 2	4 / 2	4 / 2	3 / 1	4 / 2	
Water connections VIC-TAULIC type	inches	2 1/2	2 1/2	2 1/2	2 1/2	2 1/2	2 1/2	2 1/2	2 1/2	3	3	
Height	mm	1.594	1.594	1.854	1.594	1.594	1.854	1.854	1.854	1.854	1.854	
Length	mm	1.674	1.674	2.374	1.674	1.674	2.374	2.374	2.374	2.374	2.374	
Depth	mm	772	772	877	772	772	877	877	877	877	877	
LEW-HS: Sound power level	dB(A)	73	73	73	73	73	73	73	73	73	73	
LEW-HL: Sound power level	dB(A)	71	71	71	71	71	71	71	71	71	71	
LEW HEAT PUMPS RATED TECHNICAL DATA												
Approx. capacity (kW)		310		350	370	410	450	480	480	530	570	630
Efficiency pack		3	4	4	4	4	4	4	n.a.	n.a.	n.a.	n.a.
LEW HS / HL		283	284	314	344	374	424	484	485	535	576	636
Cooling capacity	kW	319,45	322,97	357,45	390,41	422,28	470,49	541,5	526,7	587,9	627	702
Rated input power	kW	53,85	53,78	61,87	66,85	72,03	78,21	88	80,4	98,7	107,6	118,7
EER		5,93	6,01	5,78	5,84	5,86	6,02	6,16	5,89	5,95	5,86	5,92
Pressure drops, user side	kPa	41	42	51	50	49	48	49	47	57	56	68
Pressure drops, dissipator side	kPa	6	6	7	7	7	7	9	8	10	10	12
Heating capacity	kW	367,61	371,69	413,83	451,62	487,71	538,48	617,2	607,5	678,3	725,8	810
Rated input power	kW	75,13	75,62	85,81	93,13	100,44	109,69	126,8	124,8	144,7	150	173,9
COP		4,89	4,92	4,82	4,85	4,86	4,91	4,87	4,87	4,69	4,84	4,61
Pressure drops, user side	kPa	49	51	63	61	60	58	63	58	71	70	85
Pressure drops, dissipator side	kPa	36	37	44	43	42	41	42	41	49	49	59
Power supply	V - ph - Hz	400 - 3N - 50Hz										
Scroll compressors / cooling circuits	No.	3 / 1	4 / 2	4 / 2	4 / 2	4 / 2	4 / 2	4 / 2	5 / 2	5 / 2	6 / 2	5 / 2
Water connections VIC-TAULIC type	inches	3	3	3	3	3	3	3	5	5	5	5
Height	mm	1.854	1.854	1.854	1.854	1.854	1.854	1.854	1490	1490	1490	1490
Length	mm	2.374	2.374	2.374	2.374	2.374	2.374	2.374	3530	3530	3530	3530
Depth	mm	877	877	877	877	877	877	877	1200	1200	1200	1200
LEW-HS: Sound power level	dB(A)	73	73	73	75	75	75	86	84	84	85	85
LEW-HL: Sound power level	dB(A)	71	71	71	73	73	73	82	80	80	81	81

Cooling capacity refers to the following conditions: water temperature at evaporator 12/7°C – water temperature at condenser 15 - 30°C

Heating capacity: water temperature at evaporator 15-10°C, water temperature at condenser 40 - 45°C.

Sound power measured according to standards ISO 3741 - ISO 3744 and EN 29614-1

WATER CHILLERS WITH REMOTE CONDENSER

LER water chillers are units for air conditioning or cooling of process fluids, conceived for both residential and industrial use, with round-the-clock operation.

They cover a wide range of heating capacities, from 40 to 420 kW, guaranteeing a high thermodynamic efficiency and broad configurability, both in terms of accessories and cooling circuits.

LER chillers have been designed as fully enclosed units to ensure exceptionally quiet operation, so that they need not be installed in a closed-off area, and they feature an innovative rounded shape which softens their aesthetic impact.

The exclusive use of refrigerant R410A and components of utmost quality in the cooling, plumbing and electrical parts makes LER units cutting-edge chillers in terms of efficiency, reliability and noise emissions.

LER C chillers are designed for cooling only: the user circuit is set up only for the production of chilled water.

Partial heat recovery is an optional feature.

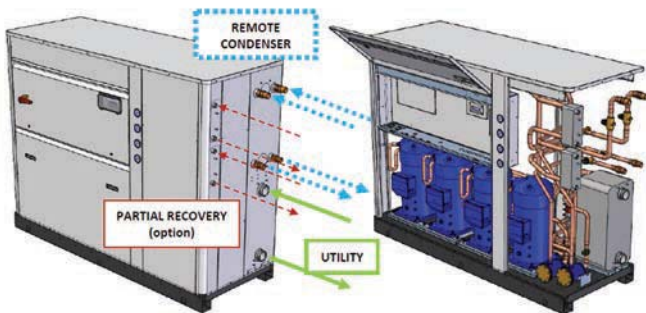

In air conditioning applications it is often requested to have heat available for the production of domestic hot water or for post-heating control in air handling units in which it is desired to have independent control of temperature and humidity.

The heat necessary can be drawn from the condensation part of the thermodynamic circuit, which is at a higher temperature.

If the withdrawal of heat is partial, the sensible heat of the gas on the outlet side is sent, via a desuperheater, toward the third thermal source at a higher temperature.

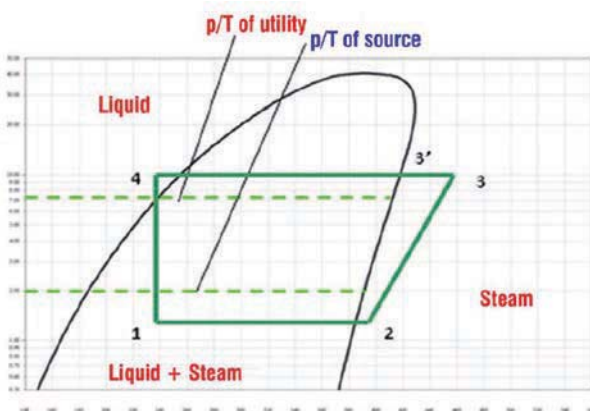

All cooling-only units of the LER series can be equipped on request with a desuperheater for partial heat recovery; the available heating capacity, which may be used, for example, for domestic hot water or post-heating coils, depends on the unit's operating conditions.

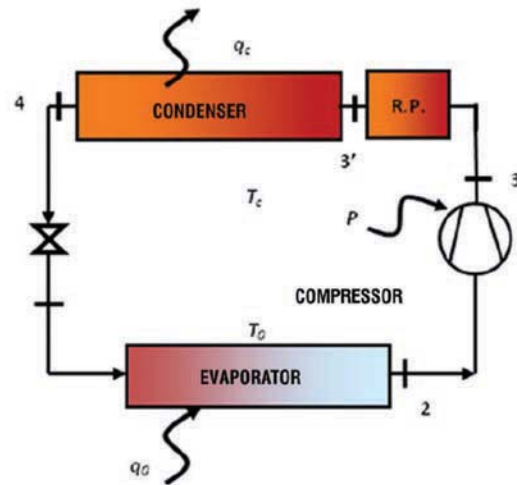

LER units provide excellent thermodynamic efficiency and utmost flexibility of use, thanks to constant product research. The combined application of scroll compressors, advanced control systems and the refrigerant gas R410A results in compact circuits and high COPs.

The possibility of maintaining the evaporator inside makes it unnecessary to add glycol to the water in the system, with clear benefits in terms of thermodynamic efficiency, protection against corrosion and respect for the environment; it also enables all components requiring routine or special maintenance to be installed in an easily accessible place.

In buildings with large surface areas, the air conditioning system can be expanded step by step as new floors or areas are sold/leased, by installing an LER unit for every floor in a small control room. This allows you to spread your investment over time.

The overall dimensions of the units (depth of less than 90 cm even in sizes with the highest capacities) enable easy installation, as they can fit through any door.

The main innovations featured in this product are summed up below:

- Possibility of using water without glycol added to it in the user circuit
- Electronically controlled electric throttle valve
- High EER (Coefficient of Performance) of the thermodynamical cycle
- Reduced refrigerant charge
- Reduced footprint (specific powers of up to 153 kW per square metre)
- Innovative aesthetics and total safety, given that the chillers are completely enclosed
- Reduced internal noise levels thanks to double sound-deadening insulation in the low noise versions

RATED TECHNICAL DATA OF LER WATER CHILLERS @ 12-7°C; condensation 50°C, glycol 0%

Efficiency pack		1	2	1	2	1	2	1	2	1	2	1	2
LER CS / CL		41	42	51	52	61	62	71	72	81	82	91	92
Cooling capacity	kW	42.4	42.4	50.2	50.2	56.9	56.9	65.2	65.2	74.1	74.1	82.9	82.9
Rated input power	kW	13.1	13.1	15.4	15.4	17.2	17.2	19.8	19.8	22.1	22.1	25	25
Pressure drops, evaporator side	kPa	27	27	37	37	30	30	37	37	29	29	35	35
Evaporator air flow rate	l/h	7286	7286	8636	8636	9785	9785	11218	11218	12738	12738	14261	14261
Scroll compressors / cooling circuits	No.	2 / 2	2 / 1	2 / 2	2 / 1	2 / 2	2 / 1	2 / 2	2 / 1	2 / 2	2 / 1	2 / 2	2 / 2
Victaulic plumbing connections	inches	2 1/2	2 1/2	2 1/2	2 1/2	2 1/2	2 1/2	2 1/2	2 1/2	2 1/2	2 1/2	2 1/2	2 1/2
Height	mm	1594	1594	1594	1594	1594	1594	1594	1594	1594	1594	1594	1594
Length	mm	1174	1174	1174	1174	1174	1174	1174	1174	1174	1174	1174	1174
Depth	mm	772	772	772	772	772	772	772	772	772	772	772	772
LER-CS: sound power level	dB(A)	69	69	69	69	69	69	70	70	70	70	70	70
LER-CL: sound power level	dB(A)	67	67	67	67	67	67	68	68	68	68	68	68
EER		3.24	3.24	3.25	3.25	3.3	3.3	3.3	3.3	3.36	3.36	3.32	3.32

Refrigerant pipes – connection to remote condenser

Pipe length	[m]	0 - 5											
Diameter of outlet line (Gas)	[mm - in]	16 - 5/8"	19 - 3/4"	16 - 5/8"	22 - 7/8"	19 - 3/4"	22 - 7/8"	19 - 3/4"	22 - 7/8"	19 - 3/4"	29 - 1 1/8"	22 - 7/8"	29 - 1 1/8"
Diameter of inlet line (Liquid)	[mm - in]	12 - 1/2"	16 - 5/8"	12 - 1/2"	19 - 3/4"	16 - 5/8"	19 - 3/4"	16 - 5/8"	19 - 3/4"	16 - 5/8"	22 - 7/8"	19 - 3/4"	22 - 7/8"
Pipe length	[m]	6 - 10											
Diameter of outlet line (Gas)	[mm - in]	16 - 5/8"	19 - 3/4"	16 - 5/8"	22 - 7/8"	19 - 3/4"	22 - 7/8"	19 - 3/4"	22 - 7/8"	19 - 3/4"	29 - 1 1/8"	22 - 7/8"	29 - 1 1/8"
Diameter of inlet line (Liquid)	[mm - in]	12 - 1/2"	16 - 5/8"	12 - 1/2"	19 - 3/4"	16 - 5/8"	19 - 3/4"	16 - 5/8"	19 - 3/4"	16 - 5/8"	22 - 7/8"	19 - 3/4"	22 - 7/8"
Pipe length	[m]	11 - 15											
Diameter of outlet line (Gas)	[mm - in]	16 - 5/8"	19 - 3/4"	19 - 3/4"	22 - 7/8"	19 - 3/4"	22 - 7/8"	19 - 3/4"	22 - 7/8"	19 - 3/4"	29 - 1 1/8"	22 - 7/8"	29 - 1 1/8"
Diameter of inlet line (Liquid)	[mm - in]	12 - 1/2"	16 - 5/8"	16 - 5/8"	19 - 3/4"	16 - 5/8"	19 - 3/4"	16 - 5/8"	19 - 3/4"	16 - 5/8"	22 - 7/8"	19 - 3/4"	22 - 7/8"
Pipe length	[m]	16 - 20											
Diameter of outlet line (Gas)	[mm - in]	16 - 5/8"	19 - 3/4"	19 - 3/4"	22 - 7/8"	19 - 3/4"	22 - 7/8"	22 - 7/8"	22 - 7/8"	22 - 7/8"	29 - 1 1/8"	22 - 7/8"	29 - 1 1/8"
Diameter of inlet line (Liquid)	[mm - in]	12 - 1/2"	16 - 5/8"	16 - 5/8"	19 - 3/4"	16 - 5/8"	19 - 3/4"	19 - 3/4"	19 - 3/4"	19 - 3/4"	22 - 7/8"	19 - 3/4"	22 - 7/8"
Pipe length	[m]	21 - 25											
Diameter of outlet line (Gas)	[mm - in]	16 - 5/8"	22 - 7/8"	19 - 3/4"	22 - 7/8"	19 - 3/4"	22 - 7/8"	22 - 7/8"	22 - 7/8"	29 - 1 1/8"	22 - 7/8"	29 - 1 1/8"	22 - 7/8"
Diameter of inlet line (Liquid)	[mm - in]	12 - 1/2"	19 - 3/4"	16 - 5/8"	19 - 3/4"	16 - 5/8"	19 - 3/4"	19 - 3/4"	19 - 3/4"	22 - 7/8"	19 - 3/4"	22 - 7/8"	19 - 3/4"

RATED TECHNICAL DATA OF LER WATER CHILLERS @ 12-7°C; condensation 50°C, glycol 0%

Efficiency pack		1	2	1	2	1	2	4	1	2	4
LER CS / CL		111	112	131	132	141	142	144	161	162	164
Cooling capacity	kW	99,6	99,6	114,2	114,2	131,1	131,1	131,1	146,7	146,7	146,7
Rated input power	kW	29,5	29,5	34	34	38,9	38,9	38,9	43,9	43,9	43,9
Pressure drops, evaporator side	kPa	30	30	37	37	35	35	35	38	38	38
Evaporator air flow rate	l/h	17138	17138	19642	19642	22553	22553	22553	25229	25229	25229
Scroll compressors / cooling circuits	No.	2 / 2	2 / 1	2 / 2	2 / 1	2 / 2	2 / 1	4-Feb	2 / 2	2 / 1	4 / 2
Victaulic plumbing connections	inches	2 1/2	2 1/2	2 1/2	2 1/2	2 1/2	2 1/2	2 1/2	2 1/2	2 1/2	2 1/2
Height	mm	1594	1594	1594	1594	1594	1594	1854	1594	1594	1854
Length	mm	1674	1674	1674	1674	1674	1674	2374	1674	1674	2374
Depth	mm	772	772	772	772	772	772	772	772	772	772
LER-CS: sound power level	dB(A)	71	71	71	71	73	73	73	73	73	73
LER-CL: sound power level	dB(A)	69	69	69	69	71	71	71	71	71	71
EER		3,38	3,38	3,36	3,36	3,37	3,37	3,37	3,34	3,34	3,34

Refrigerant pipes – connection to remote condenser

Pipe length	[m]	0 - 5									
Diameter of outlet line (Gas)	[mm - in]	22 - 7/8"	29 - 1 1/8"	29 - 1 1/8"	35 - 1 3/8"	29 - 1 1/8"	35 - 1 3/8"	29 - 1 1/8"	29 - 1 1/8"	35 - 1 3/8"	29 - 1 1/8"
Diameter of inlet line (Liquid)	[mm - in]	19 - 3/4"	22 - 7/8"	22 - 7/8"	29 - 1 1/8"	22 - 7/8"	29 - 1 1/8"	22 - 7/8"	22 - 7/8"	29 - 1 1/8"	22 - 7/8"
Pipe length	[m]	6 - 10									
Diameter of outlet line (Gas)	[mm - in]	22 - 7/8"	29 - 1 1/8"	29 - 1 1/8"	35 - 1 3/8"	29 - 1 1/8"	35 - 1 3/8"	29 - 1 1/8"	29 - 1 1/8"	35 - 1 3/8"	29 - 1 1/8"
Diameter of inlet line (Liquid)	[mm - in]	19 - 3/4"	22 - 7/8"	22 - 7/8"	29 - 1 1/8"	22 - 7/8"	29 - 1 1/8"	22 - 7/8"	22 - 7/8"	29 - 1 1/8"	22 - 7/8"
Pipe length	[m]	11 - 15									
Diameter of outlet line (Gas)	[mm - in]	22 - 7/8"	29 - 1 1/8"	29 - 1 1/8"	35 - 1 3/8"	29 - 1 1/8"	35 - 1 3/8"	29 - 1 1/8"	29 - 1 1/8"	35 - 1 3/8"	29 - 1 1/8"
Diameter of inlet line (Liquid)	[mm - in]	19 - 3/4"	22 - 7/8"	22 - 7/8"	29 - 1 1/8"	22 - 7/8"	29 - 1 1/8"	22 - 7/8"	22 - 7/8"	29 - 1 1/8"	22 - 7/8"
Pipe length	[m]	16 - 20									
Diameter of outlet line (Gas)	[mm - in]	22 - 7/8"	29 - 1 1/8"	29 - 1 1/8"	35 - 1 3/8"	29 - 1 1/8"	35 - 1 3/8"	29 - 1 1/8"	29 - 1 1/8"	35 - 1 3/8"	29 - 1 1/8"
Diameter of inlet line (Liquid)	[mm - in]	19 - 3/4"	22 - 7/8"	22 - 7/8"	29 - 1 1/8"	22 - 7/8"	29 - 1 1/8"	22 - 7/8"	22 - 7/8"	29 - 1 1/8"	22 - 7/8"
Pipe length	[m]	21 - 25									
Diameter of outlet line (Gas)	[mm - in]	22 - 7/8"	29 - 1 1/8"	29 - 1 1/8"	35 - 1 3/8"	29 - 1 1/8"	35 - 1 3/8"	29 - 1 1/8"	29 - 1 1/8"	35 - 1 3/8"	29 - 1 1/8"
Diameter of inlet line (Liquid)	[mm - in]	19 - 3/4"	22 - 7/8"	22 - 7/8"	29 - 1 1/8"	22 - 7/8"	29 - 1 1/8"	22 - 7/8"	22 - 7/8"	29 - 1 1/8"	22 - 7/8"

RATED TECHNICAL DATA OF LER WATER CHILLERS @ 12-7°C; condensation 50°C, glycol 0%

Efficiency pack		1	2	3	4	4	4	4	4	4	4	4
LER CS / CL		181	182	184	204	214	244	284	314	344	374	424
Cooling capacity	kW	171.5	171.5	171.5	183.1	197.6	231.9	265.1	294.7	317.3	343.8	379.2
Rated input power	kW	51.4	51.4	51.4	54.5	59	68	77.9	87.7	95.2	102.8	112.3
Pressure drops, evaporator side	kPa	40	40	38	38	43	24	31	37	42	40	42
Evaporator air flow rate	l/h	29501	29501	29501	31495	33980	39890	45594	50692	54579	59134	65219
Scroll compressors / cooling circuits	No.	2 / 2	2 / 1	4 / 2	4 / 2	4 / 2	4 / 2	4 / 2	4 / 2	4 / 2	4 / 2	4 / 2
VicTaulic plumbing connections	inches	2 1/2	2 1/2	2 1/2	2 1/2	2 1/2	2 1/2	3	3	3	3	3
Height	mm	1594	1594	1854	1854	1854	1854	1854	1854	1854	1854	1854
Length	mm	1674	1674	2374	2374	2374	2374	2374	2374	2374	2374	2374
Depth	mm	772	772	772	772	772	772	772	772	772	772	772
LER-CS: sound power level	dB(A)	73	73	73	73	73	73	73	73	75	75	75
LER-CL: sound power level	dB(A)	71	71	71	71	71	71	71	71	73	73	73
EER		3.34	3.34	3.34	3.36	3.35	3.41	3.4	3.36	3.33	3.35	3.38
Refrigerant pipes – connection to remote condenser												
Pipe length	[m]	0 - 5										
Diameter of outlet line (Gas)	[mm - in]	35 - 1 3/8"	41 - 1 5/8"	29 - 1 1/8"	29 - 1 1/8"	29 - 1 1/8"	35 - 1 3/8"	35 - 1 3/8"	35 - 1 3/8"	35 - 1 3/8"	41 - 1 5/8"	41 - 1 5/8"
Diameter of inlet line (Liquid)	[mm - in]	29 - 1 1/8"	35 - 1 3/8"	22 - 7/8"	22 - 7/8"	22 - 7/8"	29 - 1 1/8"	29 - 1 1/8"	29 - 1 1/8"	29 - 1 1/8"	35 - 1 3/8"	35 - 1 3/8"
Pipe length	[m]	6 - 10										
Diameter of outlet line (Gas)	[mm - in]	35 - 1 3/8"	41 - 1 5/8"	29 - 1 1/8"	29 - 1 1/8"	29 - 1 1/8"	35 - 1 3/8"	35 - 1 3/8"	35 - 1 3/8"	35 - 1 3/8"	41 - 1 5/8"	41 - 1 5/8"
Diameter of inlet line (Liquid)	[mm - in]	29 - 1 1/8"	35 - 1 3/8"	22 - 7/8"	22 - 7/8"	22 - 7/8"	29 - 1 1/8"	29 - 1 1/8"	29 - 1 1/8"	29 - 1 1/8"	35 - 1 3/8"	35 - 1 3/8"
Pipe length	[m]	11 - 15										
Diameter of outlet line (Gas)	[mm - in]	35 - 1 3/8"	41 - 1 5/8"	29 - 1 1/8"	29 - 1 1/8"	29 - 1 1/8"	35 - 1 3/8"	35 - 1 3/8"	35 - 1 3/8"	35 - 1 3/8"	41 - 1 5/8"	41 - 1 5/8"
Diameter of inlet line (Liquid)	[mm - in]	29 - 1 1/8"	35 - 1 3/8"	22 - 7/8"	22 - 7/8"	22 - 7/8"	29 - 1 1/8"	29 - 1 1/8"	29 - 1 1/8"	29 - 1 1/8"	35 - 1 3/8"	35 - 1 3/8"
Pipe length	[m]	16 - 20										
Diameter of outlet line (Gas)	[mm - in]	35 - 1 3/8"	41 - 1 5/8"	29 - 1 1/8"	29 - 1 1/8"	29 - 1 1/8"	35 - 1 3/8"	35 - 1 3/8"	35 - 1 3/8"	35 - 1 3/8"	41 - 1 5/8"	41 - 1 5/8"
Diameter of inlet line (Liquid)	[mm - in]	29 - 1 1/8"	35 - 1 3/8"	22 - 7/8"	22 - 7/8"	22 - 7/8"	29 - 1 1/8"	29 - 1 1/8"	29 - 1 1/8"	29 - 1 1/8"	35 - 1 3/8"	35 - 1 3/8"
Pipe length	[m]	21 - 25										
Diameter of outlet line (Gas)	[mm - in]	35 - 1 3/8"	41 - 1 5/8"	29 - 1 1/8"	29 - 1 1/8"	29 - 1 1/8"	35 - 1 3/8"	35 - 1 3/8"	35 - 1 3/8"	35 - 1 3/8"	41 - 1 5/8"	41 - 1 5/8"
Diameter of inlet line (Liquid)	[mm - in]	29 - 1 1/8"	35 - 1 3/8"	22 - 7/8"	22 - 7/8"	22 - 7/8"	29 - 1 1/8"	29 - 1 1/8"	29 - 1 1/8"	29 - 1 1/8"	35 - 1 3/8"	35 - 1 3/8"

dedicated controls
solutions

SUPERVISION SOFTWARE
MYCHILLER
MYCHILLER ACS

SUPERVISION SOFTWARE

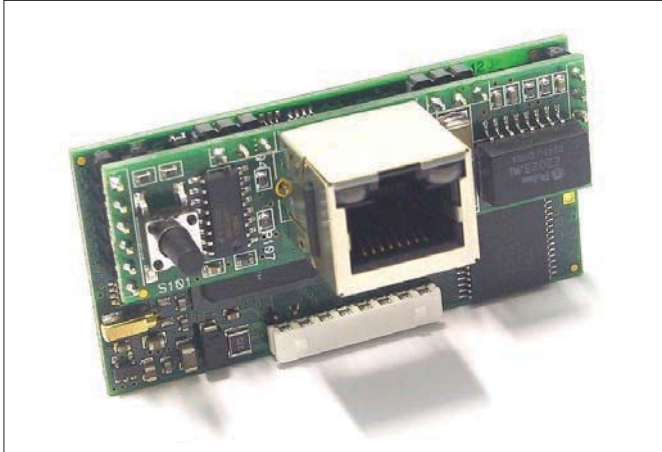

TECHNICAL CHARACTERISTICS

- Ethernet Connection RJ45 10Mbps
- Linux operating system 2.4.21

INSTALLATION

- Direct installation on the serial port of the advanced controller
- Static or dynamic IP address with DHCP function

WEB SERVER FUNCTION

- Display of unit status
- Display of current alarms and alarm history
- Data recording 10 settable variables
- Record download via web browser or FTP
- Editing of main parameters
- Sending of e-mail to 5 recipients in case of alarm

CONNECTION IN SUPERVISION SYSTEM

- With SNMP v1 & v2c protocol
- With BACnet Ethernet or BACnet/IP protocol



TOUCH SCREEN GRAPHIC DISPLAY



TECHNICAL CHARACTERISTICS

- 1/4 VGA colour Display
- 5.7" Touch screen
- 320x240 pixel Resolution
- Buzzer alarm

VERSIONS

- Board installation model
- Wall-mounted model with separate kit

FUNCTIONALITY

- Connection of multiple units in LAN
- Display of system status
- Display of individual connected units
- Display of temperature and humidity graphs
- Editing of main parameters in local mode (for individual units) or in global mode (for all units)

COMMUNICATION PROTOCOLS

- CAREL PROPRIETARY
- MODBUS®
- LONWORKS
- BACNET
- SNMP
- TREND
- OPC

APPLICABLE TO

The solution can be adopted in all water chillers and heat pumps equipped with advanced microprocessor control.

REMOTE CONTROL PANEL FOR CHILLER

MYCHILLER is the new remote control for Galletti water chillers and heat pumps that simplifies and improves management thanks to the large LCD display and the possibility to view and edit the main operating parameters.

Designed to complement the controls for MYCOMFORT hydronic units and available in two BASE and PLUS versions, MYCHILLER is the natural aesthetic and functional development and allows the remote management of the Carel μ chiller2, μ chiller2 SE, pCO1 and pCOXS electronic panels. It can therefore be applied to all air-cooled and water-cooled, outdoor or indoor, water chillers.

SIMPLE INSTALLATION

All that is needed is a bus connection with AWG24 cable to ensure communication between the unit and the control.

ACCESSING THE REGULATION FUNCTIONS

MyCHILLER makes it possible to change the temperature of cold water production (hot water in case of heat pumps) without using the controller installed in the unit whose access is sometimes difficult.

THE SEASONS AT HAND

The transition from heating to cooling only requires the push of a button and the display is ensured by special icons on the LCD display panel.

SIMPLIFIED MAINTENANCE

With its large display, MyCHILLER can also monitor the advanced parameters characteristic of the cooling cycle and thus facilitates diagnostics in case of malfunctions.

ALARMS UNDER CONTROL

The rapid detection of the alarm code is essential to optimize and speed up the service interventions: MYCHILLER immediately make this information available, which are normally accessible only on the unit.

SIMPLE INSTALLATION

ALL that is needed is a bus connection with AWG24 cable to ensure communication between the unit and the control.

Accessing the regulation functions

MYCHILLER makes it possible to change the temperature of cold water production (hot water in case of heat pumps) without using the controller installed in the unit whose access is sometimes difficult.

The seasons at hand

The transition from heating to cooling only requires the push of a button and the display is ensured by special icons on the LCD display panel.

MYCHILLER can also monitor the advanced parameters characteristic of the cooling cycle and thus facilitates diagnostics in case of malfunctions.

Alarms under control

The rapid detection of the alarm code is essential to optimize and speed up the service interventions: MYCHILLER immediately make this information available, which are normally accessible only on the unit.



ENERGY SAVING

The ECONOMY function makes it possible to correct the set-point in order to reduce energy consumption. This function can be activated directly from the keyboard, or through the closing of the contact by means of a digital input.

PROGRAMMABLE

Through the weekly clock incorporated in the PLUS version it is possible to set for every day of the week the unit status or the operating temperature level.

COMPARATIVE CHARACTERISTICS	BASE	LARGE
Reading and changing of unit parameters	X	X
Alarm reading	X	X
Configurable ON/OFF digital input	X	X
Incorporated clock		X
ON/OFF setpoint by time slots		X

MICROPROCESSOR CONTROL FOR HEAT PUMPS AND DHW PRODUCTION

The MYCHILLER ACS remote controller can simultaneously manage a heat pump connected via a serial connection and demands for domestic hot water (via a probe or digital input) by modifying the heat pump setpoint and activating a diverter valve.

The production of domestic hot water through a heat exchange with technical water produced by a heat pump requires suitable temperature levels, under the foreseen working conditions, which should thus be verified on the technical datasheets of the individual units.

If an enabled user demands DHW, the controller switches off the heat pump, waits for the internal pump of the chiller to switch off, activates the diverter valve and - after a delay necessary for positioning the valve - switches on the heat pump in the heating mode, setting a specific DHW setpoint at the same time.

Once the demand for DHW has been satisfied, the controller restores the previous heating setpoint, switches off the unit, waits for the internal pump of the unit to switch off and - after the delay necessary for positioning the valve - switches the heat pump back on in the operating mode it was in before the demand for DHW.

If the user is disabled, the heat pump will normally be in an off state and be switched on by the controller only in the presence of a demand for DHW, and then return into an off state once it has finished producing hot water.

This type of operation may prove useful during the spring/autumn season when only the production of DHW is required.

If outdoor temperatures prevent the heat pump from producing water that is hot enough for sanitary use, the controller can activate a supplemental heating element via a 230V output. It will be switched on if the temperature of the outdoor air and of the water leaving the heat pump falls below two thresholds which can be set from the advanced parameters menu.



If a demand for DHW comes during defrosting of the heat pump, the controller will wait for it to be completed and only then switch on the unit to produce DHW.

If the controller is used in a system with hydraulic separation between the primary and secondary circuits, it can control a booster pump on the user side.

It is necessary to enable the function from the main parameters menu and connect an additional remote probe in the home interior. In the heating mode, the pump is switched on if the temperature falls below a threshold which can be set from the advanced parameters menu and switched off when the threshold+ hysteresis has been exceeded; in the cooling mode the logic is reversed.

FUNCTIONAL DIAGRAM WITH REVERSIBLE HEAT PUMP CONNECTED TO HEATING/AIR CONDITIONING SYSTEM AND BUFFER TANK FOR DHW PRODUCTION.

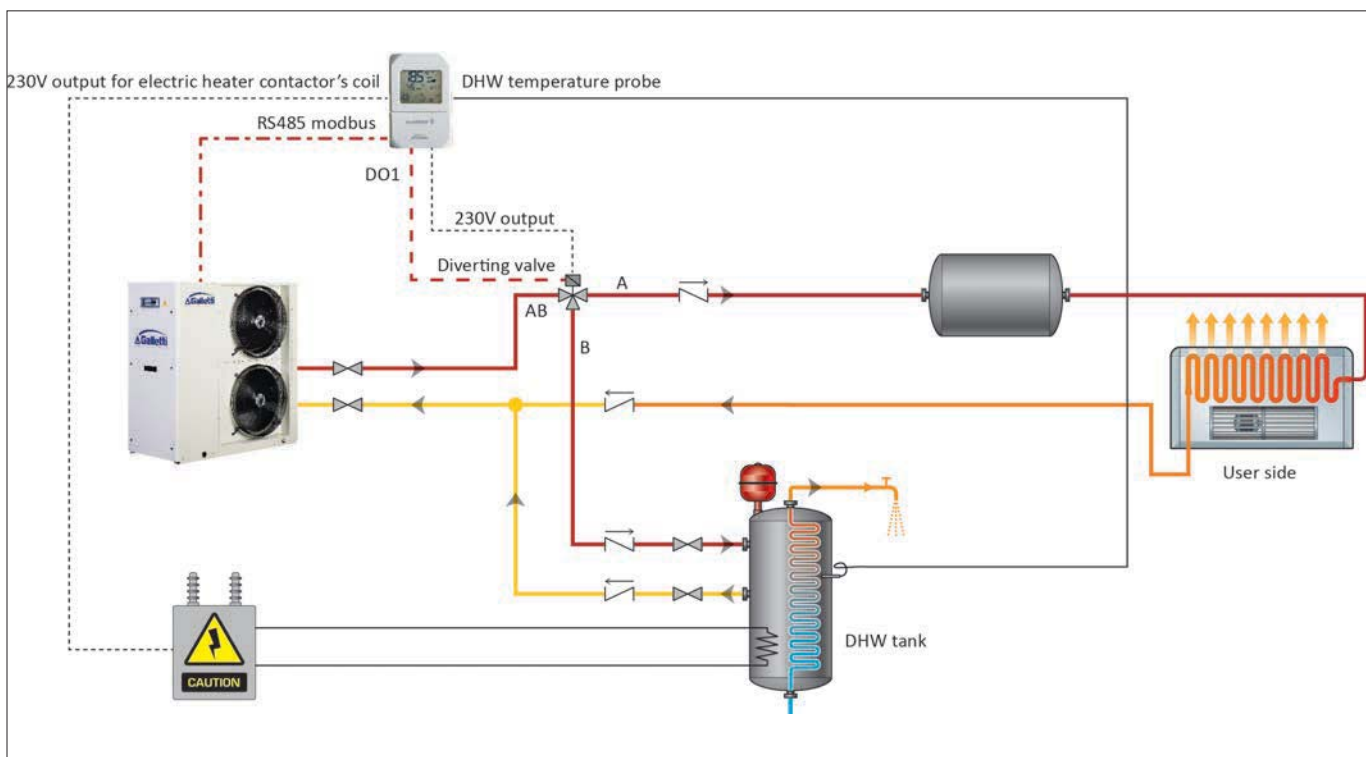

MAIN FUNCTIONS AND FEATURES:

- Switching on/off of the unit
- Control over the temperature setpoint of water entering the evaporator
- Selection of summer/winter mode
- Reading and changing of main unit parameters (differentials, minimum and maximum setpoints)
- Reading of advanced parameters (temperature of water leaving evaporator, condensation pressure)
- Display of active alarms on the unit
- Control of a buffer tank for domestic hot water
- No-voltage contact for external activation which may enable or disable unit operation
- No-voltage contact for remote enabling of the DHW mode
- Control of a diverter valve via a digital output
- Control of a booster pump on the user side
- Control of a supplemental heating element for DWH production
- The DHW MYCHILLER control panel is always supplied complete with a three-way valve for diverting technical water between the heating/air conditioning side and the tank side for the production of DHW.

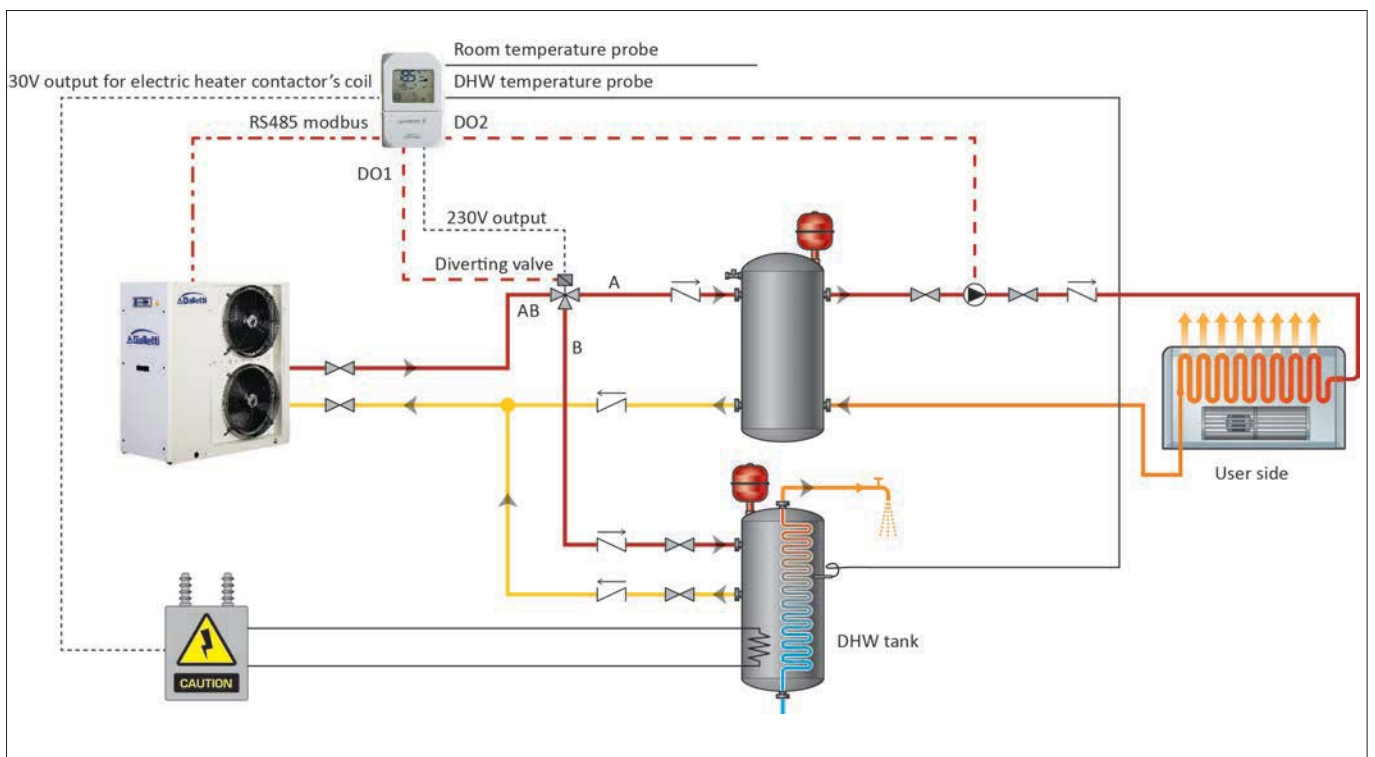
FUNCTIONAL DIAGRAM WITH REVERSIBLE HEAT PUMP CONNECTED TO HEATING/AIR CONDITIONING SYSTEM VIA TANK WITH 4 CONNECTIONS AND BUFFER TANK FOR DHW PRODUCTION.



Via Romagnoli 12/a - 40010 Bentivoglio Bologna Italia
Tel. +39 051 8908111 fax +39 051 8908122
www.galletti.it - info@galletti.it